

Machine Tending Kits from EMI

Machine Tending Kits from EMI are a perfect starting point for tending machine centers, such as CNC mills and lathes. With multiple mounting configurations available, these kits can be used in a wide variety of applications.

Features:

- Mounts directly to ISO 9409-1-50-4-M6 robot flange (hardware included).
- Mounting options include dual gripper set up in a 90° or 180° configuration and single gripper 180°.
- Two-Jaw & Three-Jaw gripper options available in each mounting option.
- Grippers can be mounted in multiple orientations.
- All kits include stock, adjustable gripping jaws.
- Includes EMI's Essentials Tool Kit (Q# 8110 see page 250).
- Each gripper includes a multi-output, programmable sensor (PNP).
- Includes blow-off manifold, nozzle kit and blocking plate.
- Operates via filtered, lubricated / unlubricated compressed air (nominal pressure, 87 psi).

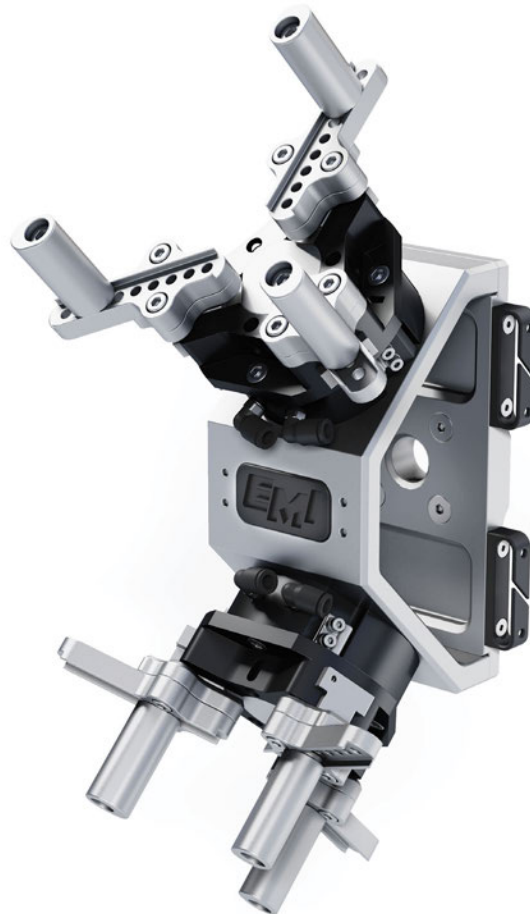

**Now available with
SCHUNK Grippers!**

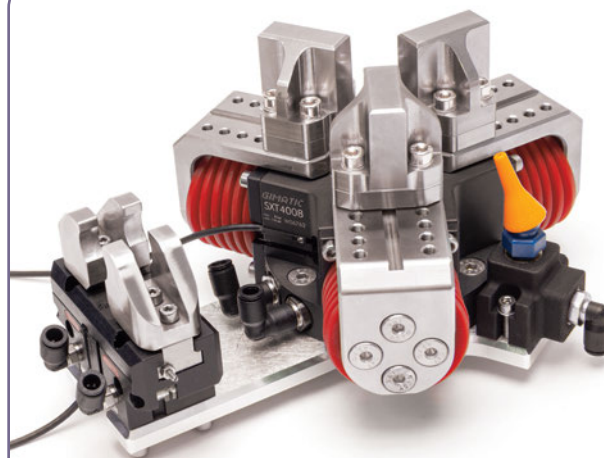
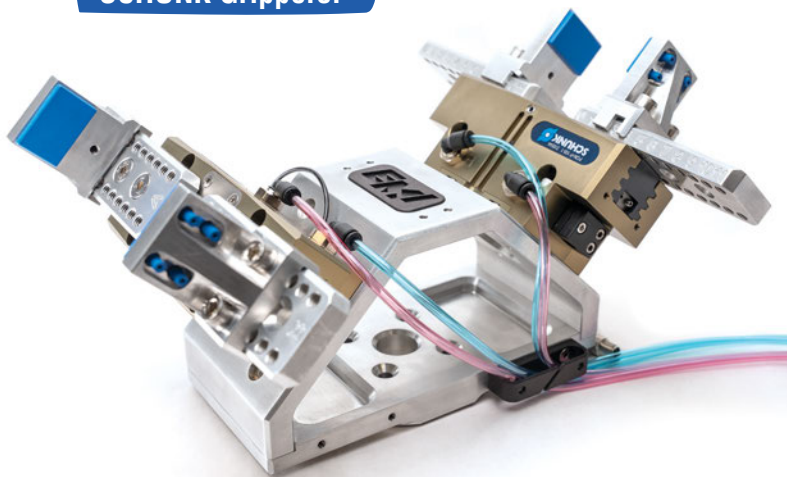

**Need a custom solution?
EMI can provide that too!** 

Our Machine Tending Datasheet is online, Click here!

Automate Your Machine Tending Process!

See page 8 for Machine Tending Application Examples

- CU
- QC
- VG
- VC
- VA
- SG
- GR
- MT**
- AC
- CS
- CC

D90 Parallel and Concentric Gripper Kits p.238

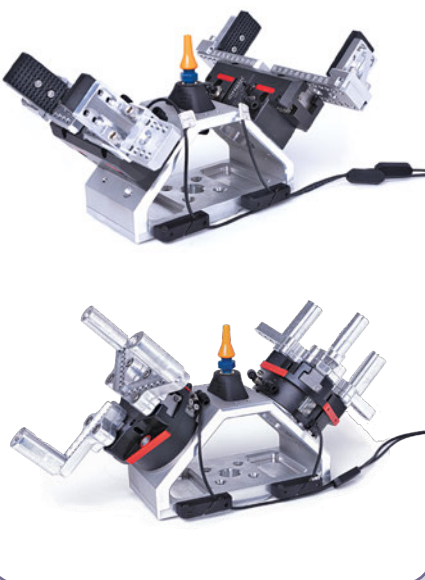

D180 Parallel and Concentric Gripper Kits p.242



S180 Parallel and Concentric Gripper Kits p.246



SCHUNK PGN p.252



SCHUNK PZN p.253



SCHUNK Accessories p.254

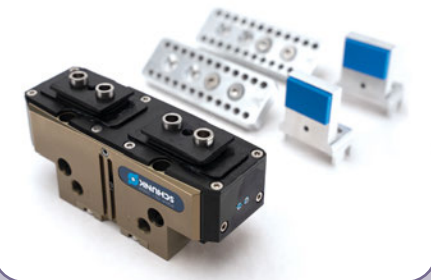

Filter Regulator Assembly p.250



3-Station Valve Assembly p.250



Custom Applications p.8



Machine Tending Kits from EMI

Step 1: Select a Mounting Configuration



D90: Dual Gripper 90°



D180: Dual Gripper 180°



S180: Single Gripper 180°

Step 2: Select a Two or Three Jaw Gripper



2-Jaw Grippers

- Gimatic DH4410: Shorter Stroke, Higher Grip Force
- Gimatic DH4420: Longer Stroke, Lower Grip Force
- PGN-plus-P 100-1: Longer Stroke, Lower Grip Force (IP40)
- PGN-plus-P 100-2: Shorter Stroke, Higher Grip Force (IP40)
- Optional SCHUNK Dust Cover: IP 64



3-Jaw Grippers

- Gimatic TH5404: Shorter Stroke, Higher Grip Force
- Gimatic TH5408: Longer Stroke, Lower Grip Force
- PZN-plus 80-1: Longer Stroke, Lower Grip Force (IP40)
- PZN-plus 80-2: Shorter Stroke, Higher Grip Force (IP40)
- Optional SCHUNK Dust Cover: IP 64

Step 3: Select Pneumatics Control Package (optional)

Control your EMI Machine Tending Kit with our pre-configured and pre-assembled, 3-station pneumatic solenoid valve kit and filter/regulator assembly. Perfect for controlling two grippers and blow-off nozzle. See page 250 for more information.

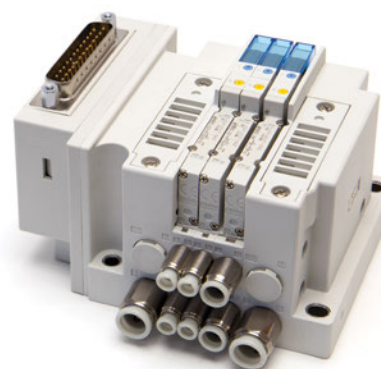

Machine Tending Kit Features

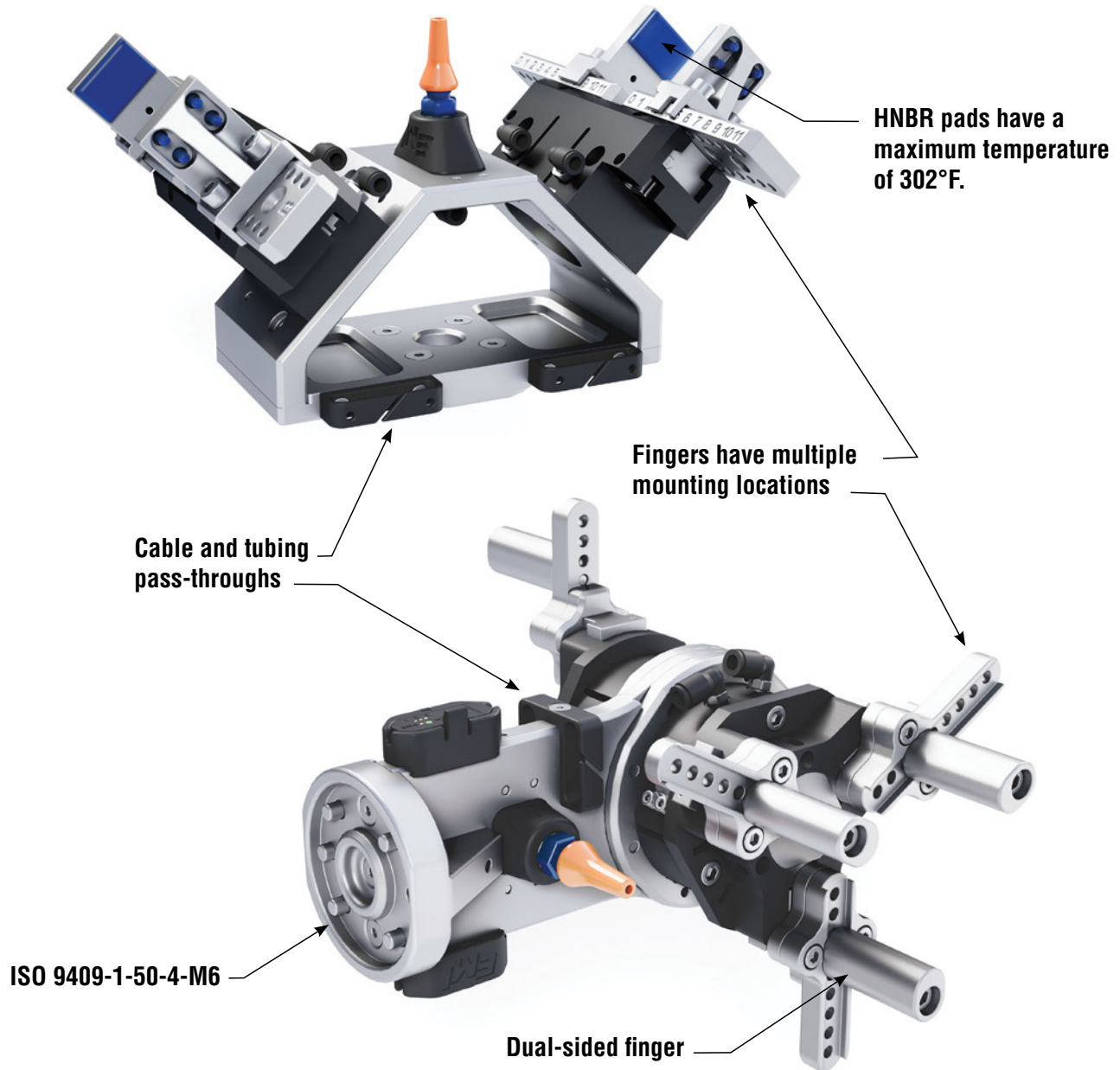

Blow-off nozzle with nozzle kit

**Includes cover plate if nozzle is not needed.*



Teachable 3-Position sensor

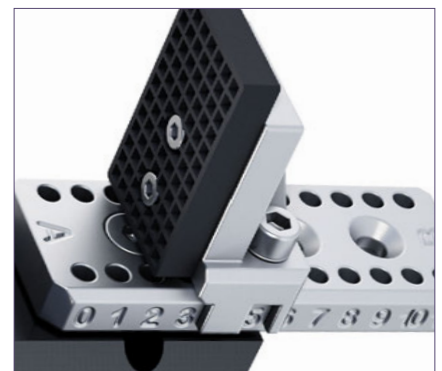

DH Grippers with replaceable HNBR and rubber pads

Machine Tending – D90 Parallel and Concentric Gripper Kits

D90 Kit Features:

- Gimatic DH or TH self-centering, pneumatic grippers at a 90° mounting configuration.
- Two-Jaw kits include aluminum jaws, and HNBR & rubber pad options. They feature a reversible finger base for increased gripping range.
- Three-Jaw kits include dual-sided gripper fingers to accommodate a larger variety of grip ranges.
- Both kits can be used to pick either external (closed grip) or interior surfaces (open grip).
- Two-Jaw grippers can be mounted in multiple 90° orientations.
- Three-Jaw grippers can be mounted in multiple 60° orientations.
- See EMI website for more information on DH & TH grippers.



Quick#	8111	8112	8117	8118
Part#	CRK-DH4410-D90-A	CRK-DH4420-D90-A	CRK-TH5404-D90-A	CRK-TH5408-D90-A
Price	\$4,195.00	\$4,195.00	\$4,295.00	\$4,295.00
Mount configuration				
Operating pressure range	36–116 psi			
Gripper stroke	2x5mm	2x10mm	3x4mm	3x8mm
Gripper type	2x DH4410	2x DH4420	2x TH5404	2x TH5408
Closing force w/stock jaws	247.3 lbf	123.6 lbf	370.9 lbf	185.5 lbf
Kit Operating Grip Range*^	0–160mm	0–170mm	0–150mm	0–158mm
Maximum work piece mass***^	6.2 kg	3.0 kg	8.9 kg	4.4 kg
Weight	3.31 kg	3.27 kg	3.29 kg	3.27 kg

*Minimum to maximum external grip range with the included stock finger kit.

**Indicates usage at 87psi with stock finger kit with dry & clear surface conditions. Varies based on grip style, orientation, materials and input pressure.

^ Values may vary based on certain application conditions. See online product page for more detailed information.

Machine Tending – D90 Parallel and Concentric Gripper Kits

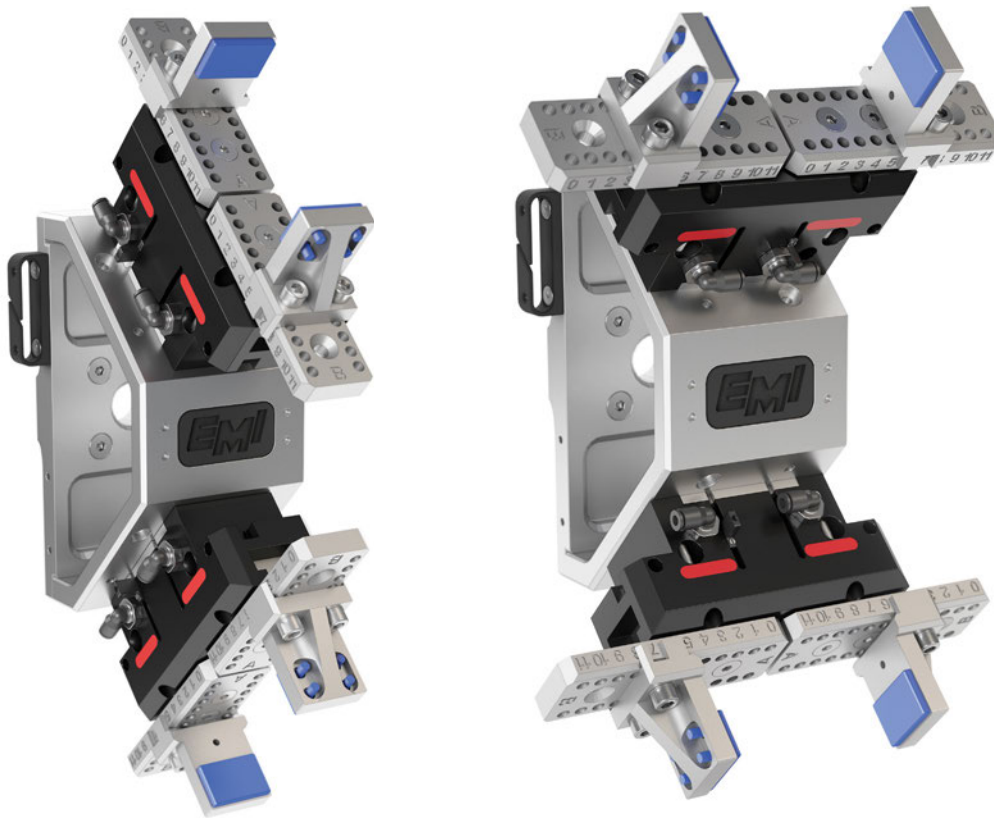

- CU
- QC
- VG
- VC
- VA
- SG
- GR
- MT**
- AC
- CS
- CC

Grippers can be mounted horizontally or vertically.

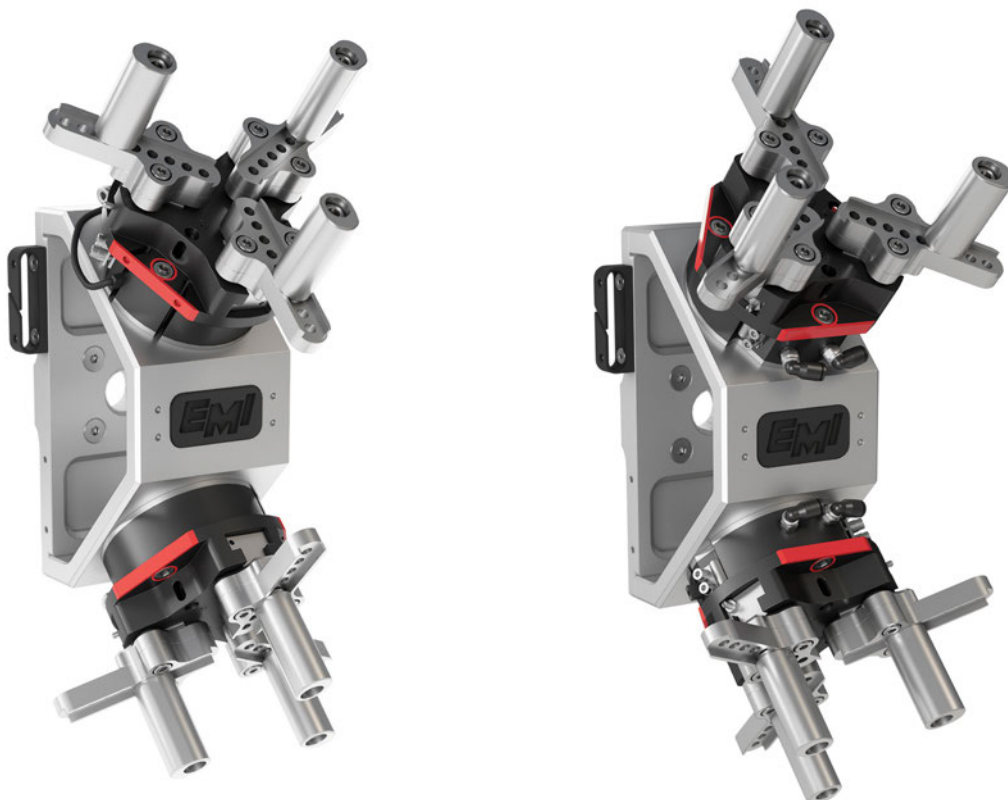

Machine Tending – 2-Jaw D-90 Parallel Gripper Kits

Quick#'s 8111 & 8112 Dimensions

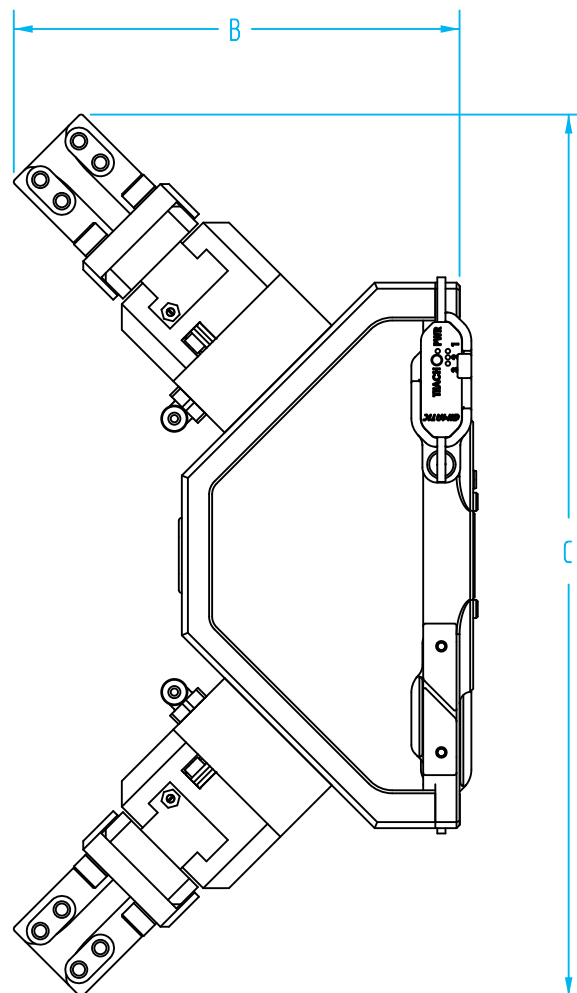
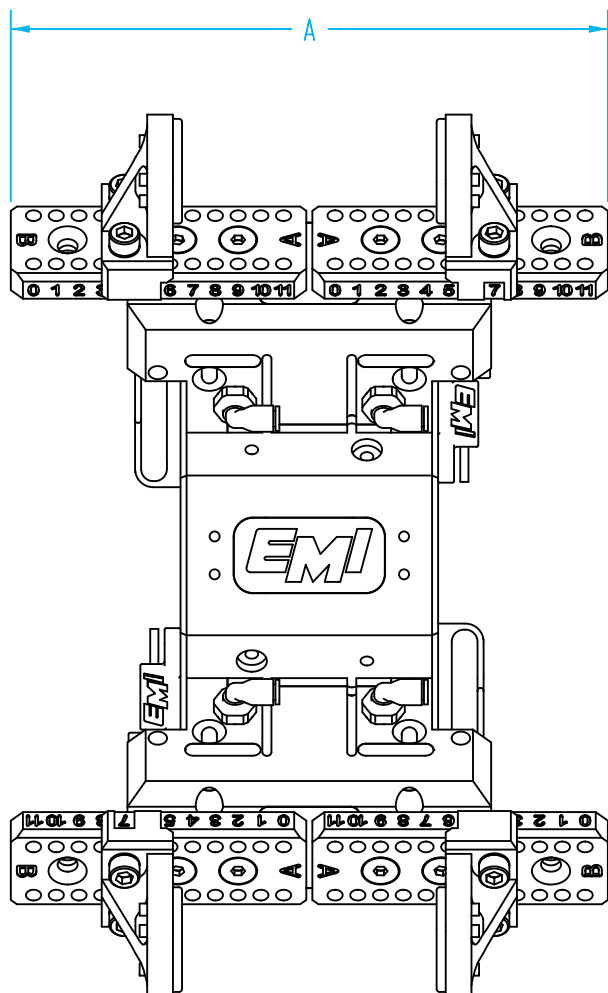

Horizontal Gripper Orientation

Quick#	A (Width)	B (Depth)	C (Height)
8111	214.5 mm	197.0 mm	300.2 mm
8112	224.5 mm		

Vertical Gripper Orientation

Quick#	A (Width)	B (Depth)	C (Height)
8111	100 mm	201.4 mm	400.2 mm
8112		205 mm	407.4 mm

All dimensions represent the maximum value with the gripper in an OPEN configuration. Dimensions may vary based on finger type and position.

Machine Tending – 3-Jaw D-90 Concentric Gripper Kits

Quick#'s 8117 & 8118 Dimensions

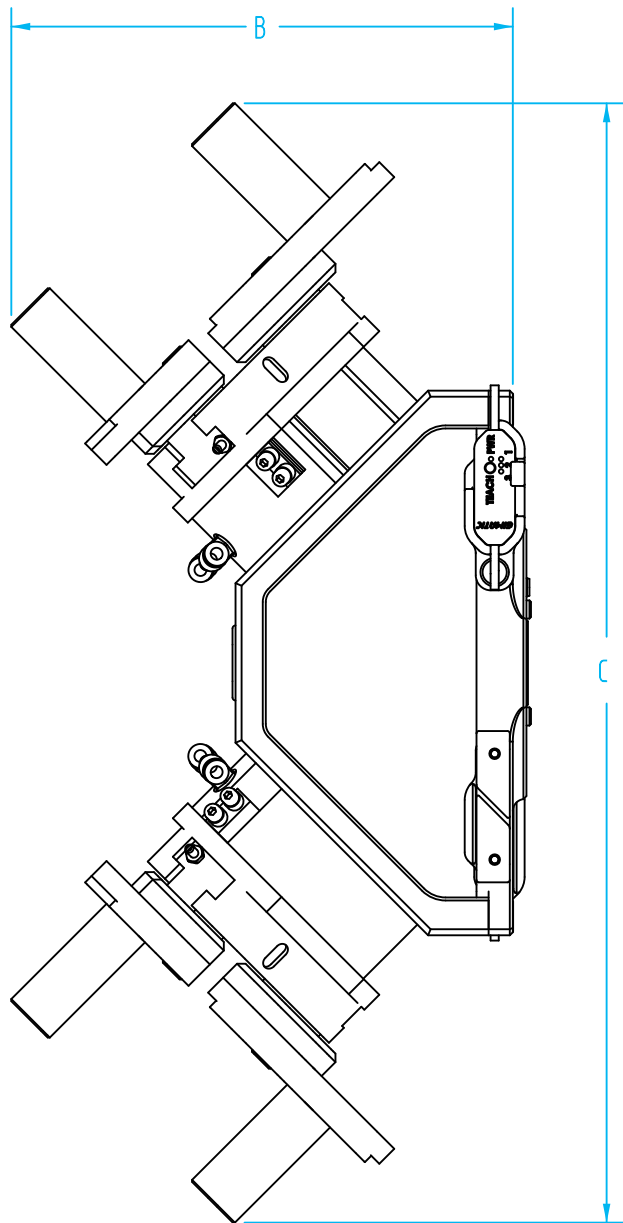
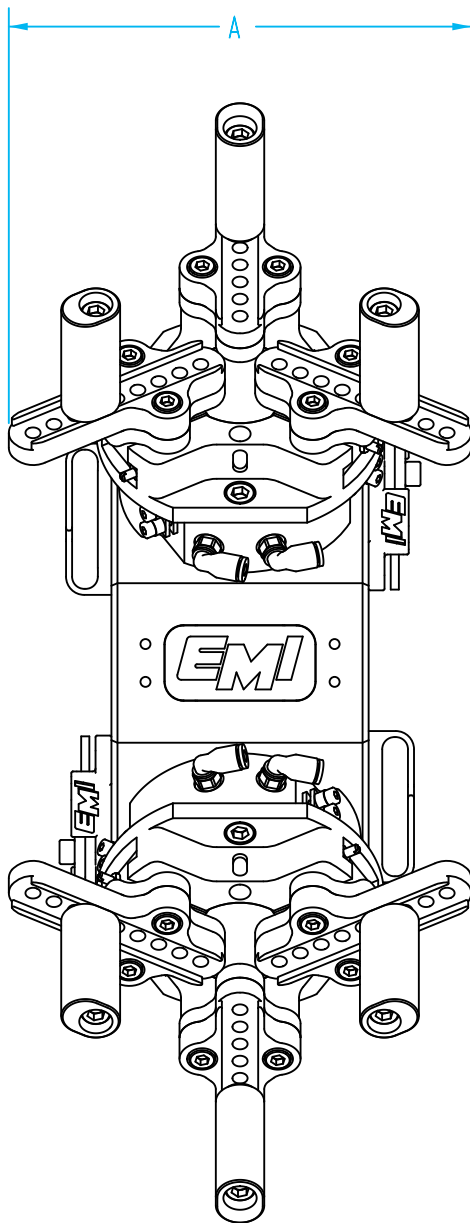

- CU
- QC
- VG
- VC
- VA
- SG
- GR
- MT**
- AC
- CS
- CC

Horizontal Gripper Orientation

Quick#	A (Width)	B (Depth)	C (Height)
8117	166.7mm	175.7mm	409.5mm
8118	173.6mm	177.1mm	415.2mm

Vertical Gripper Orientation

Quick#	A (Width)	B (Depth)	C (Height)
8117	166.7mm	206.4mm	348.0mm
8118	173.6mm	209.2mm	350.8mm

All dimensions represent the maximum value with the gripper in an OPEN configuration. Dimensions may vary based on finger type and position.

Machine Tending – D180 Parallel and Concentric Gripper Kits

D180 Kit Features:

- Gimatic DH or TH self-centering, pneumatic grippers at an 180° mounting configuration.
- Two-Jaw kits include aluminum jaws, and HNBR & rubber pad options. They feature a reversible finger base for increased gripping range.
- Three-Jaw kits include dual-sided gripper fingers to accommodate a larger variety of grip ranges.
- Both kits can be used to pick either external (closed grip) or interior surfaces (open grip).
- Two-Jaw grippers can be mounted in multiple 90° orientations.
- Three-Jaw grippers can be mounted in multiple 90° orientations.
- See EMI website for more information on DH & TH grippers.

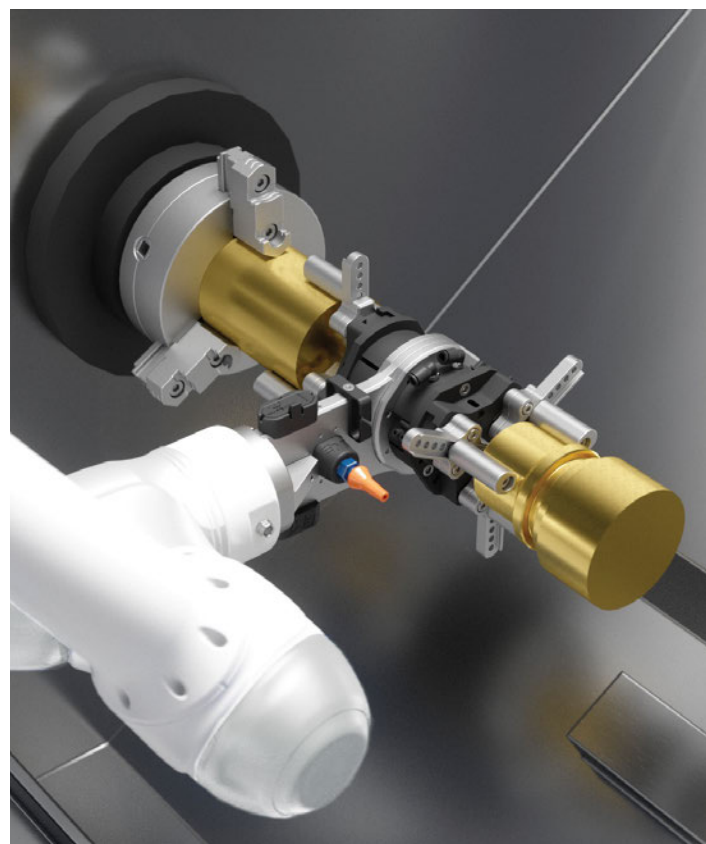

Quick#	8113	8114	8119	8120
Part#	CRK-DH4410-D180-A	CRK-DH4420-D180-A	CRK-TH5404-D180-A	CRK-TH5408-D180-A
Price	\$3,695.00	\$3,695.00	\$3,795.00	\$3,795.00
Mount configuration				
Operating pressure range	36–116 psi			
Gripper stroke	2x5mm	2x10mm	3x4mm	3x8mm
Gripper type	2x DH4410	2x DH4420	2x TH5404	2x TH5408
Closing force w/stock jaws	247.3 lbf	123.6 lbf	370.9 lbf	185.5 lbf
Kit Operating Grip Range*^	0–160mm	0–170mm	0–150mm	0–158mm
Maximum work piece mass***^	6.2 kg	3.0 kg	8.9 kg	4.4 kg
Weight	3.15 kg	3.11 kg	3.12 kg	3.10 kg

*Minimum to maximum external grip range with the included stock finger kit.

**Indicates usage at 87psi with stock finger kit with dry & clear surface conditions. Varies based on grip style, orientation, materials and input pressure.

^ Values may vary based on certain application conditions. See online product page for more detailed information.

[Use Quick#s for easy online ordering.](#)

Machine Tending – D180 Parallel and Concentric Gripper Kits

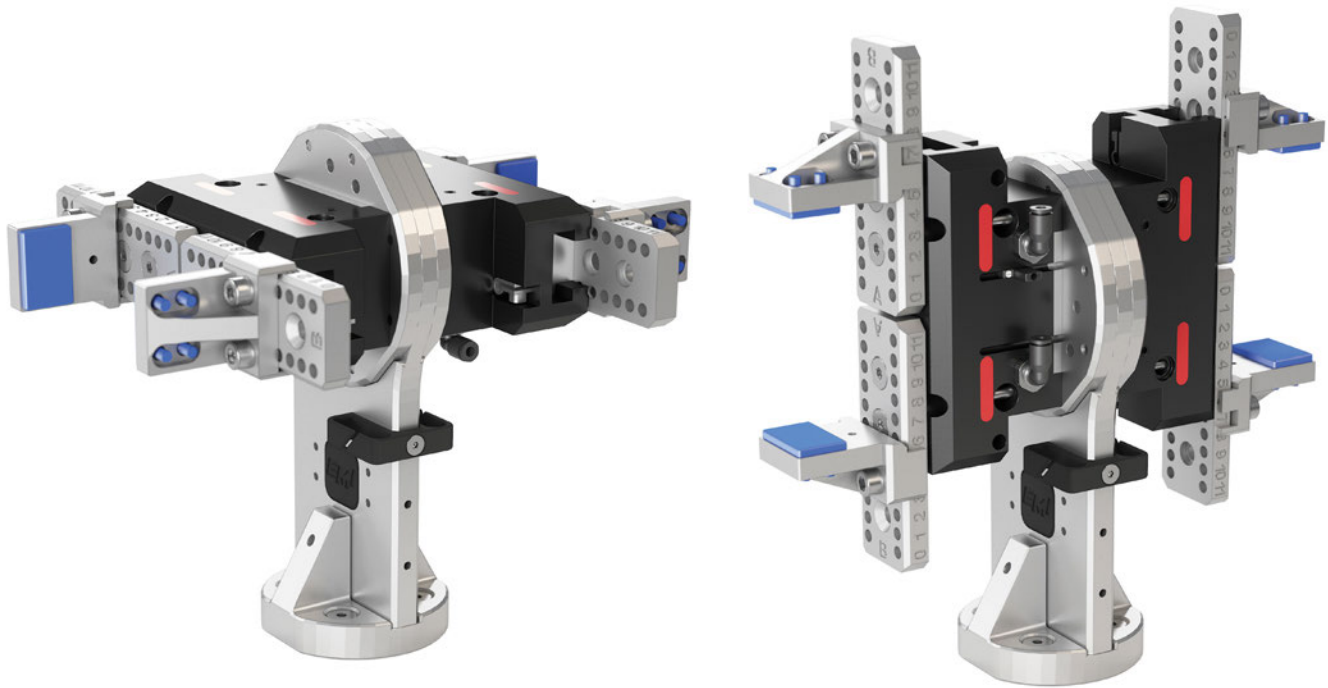

Grippers can be mounted horizontally or vertically.

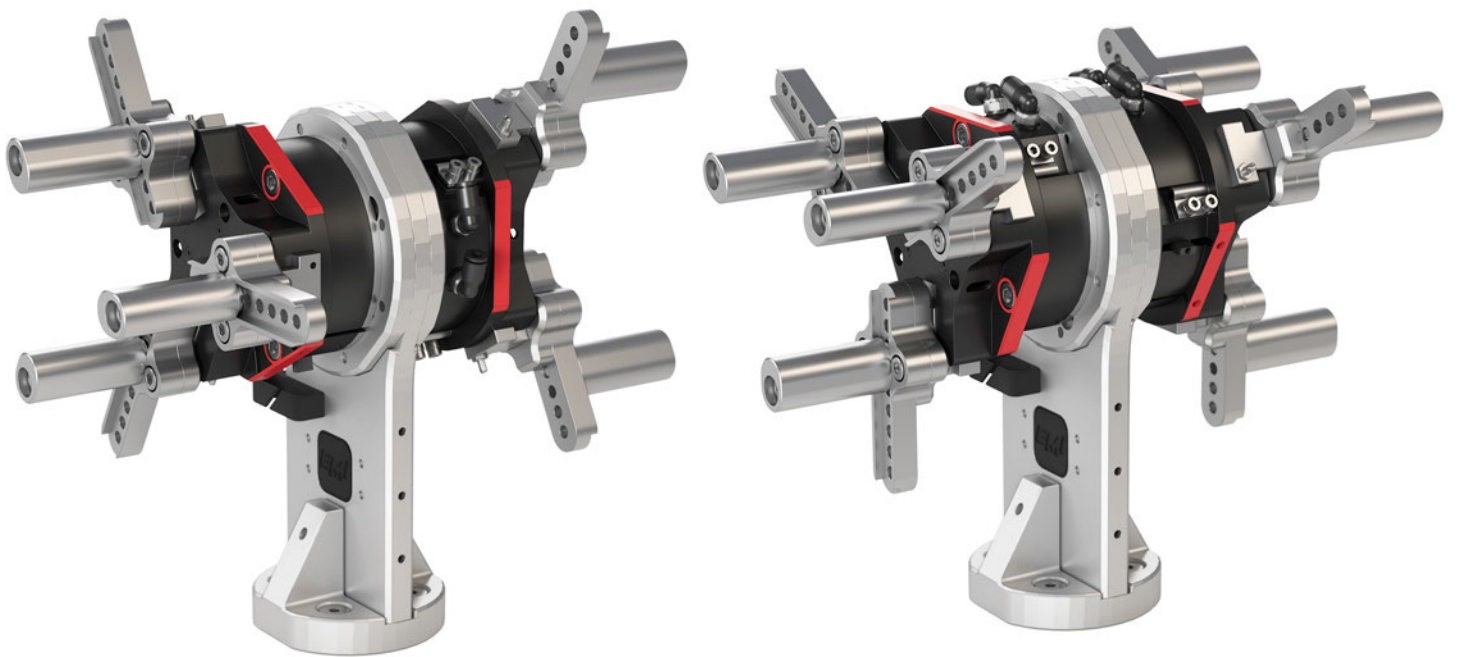

Machine Tending – 2-Jaw D-180 Parallel Gripper Kits

Quick#'s 8113 & 8114 Dimensions

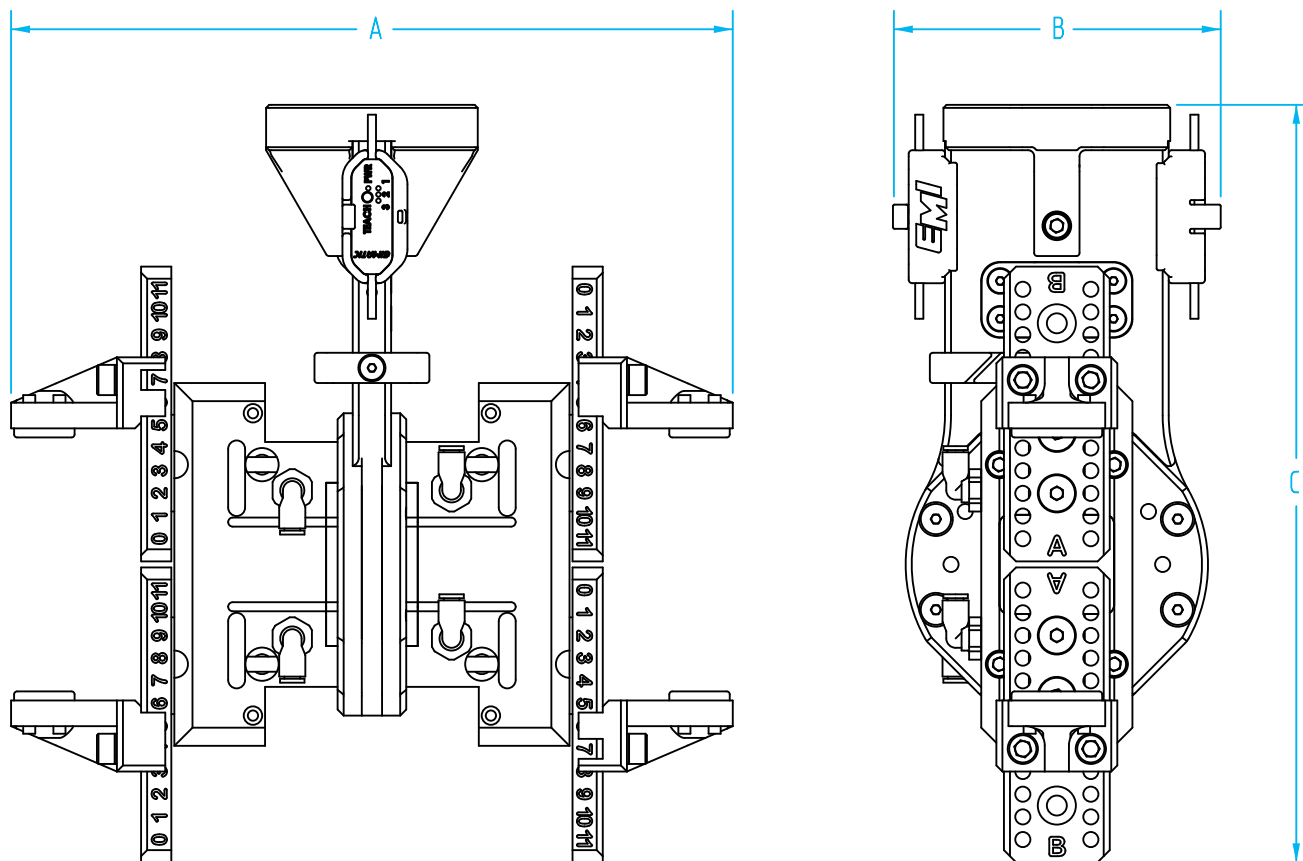

Horizontal Gripper Orientation

Quick#	A (Width)	B (Depth)	C (Height)
8113	256.7mm	108.4mm	253.8mm
8114			258.8mm

Vertical Gripper Orientation

Quick#	A (Width)	B (Depth)	C (Height)
8113	256.7mm	214.5mm	196.5mm
8114		224.5mm	

All dimensions represent the maximum value with the gripper in an OPEN configuration.
 Dimensions may vary based on finger type and position.

Machine Tending – 3-Jaw D-180 Concentric Gripper Kits

Quick#'s 8119 & 8120 Dimensions

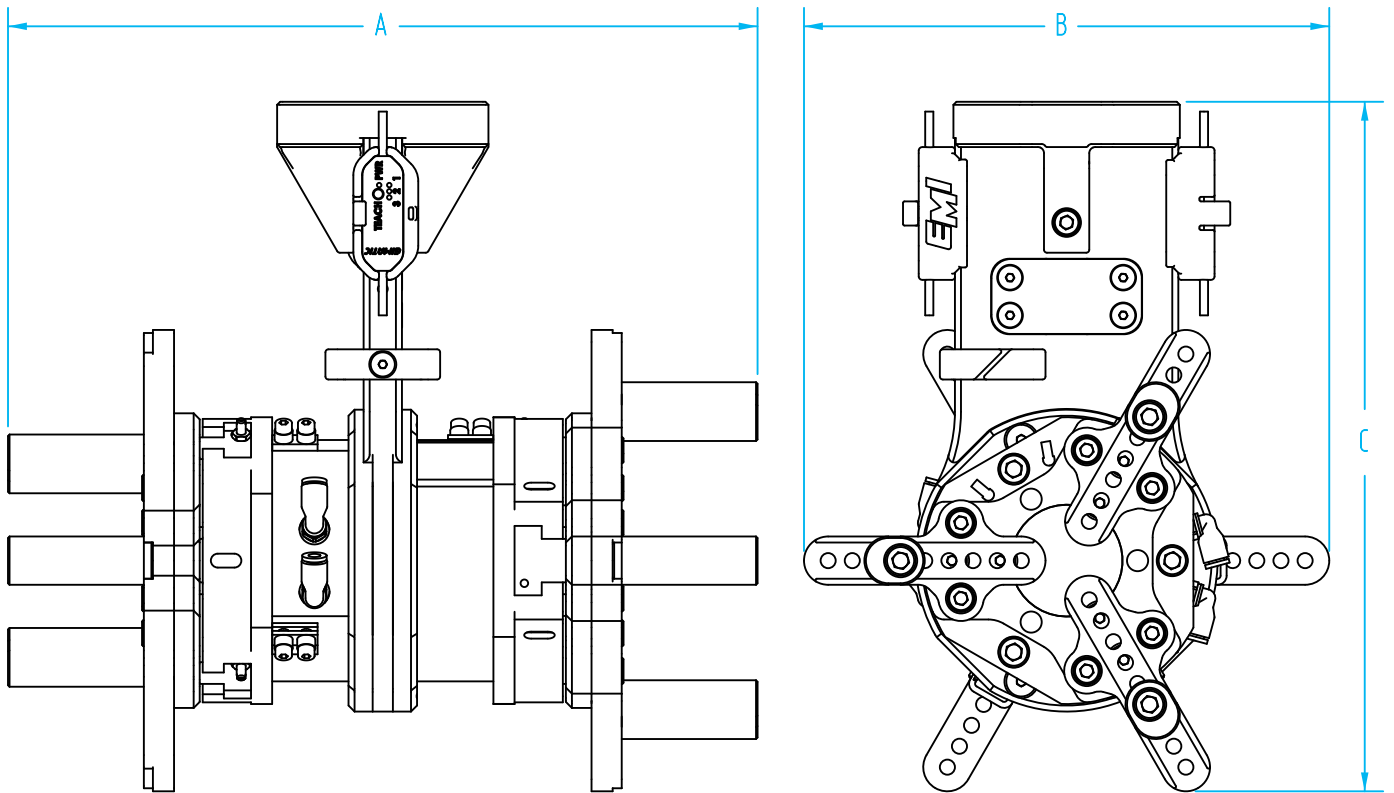

- CU
- QC
- VG
- VC
- VA
- SG
- GR
- MT**
- AC
- CS
- CC

Horizontal Gripper Orientation

Quick#	A (Width)	B (Depth)	C (Height)
8119	248.3mm	157.6mm	243.0mm
8120		161.6mm	247.0mm

Vertical Gripper Orientation

Quick#	A (Width)	B (Depth)	C (Height)
8119	248.3mm	182.0mm	230.8mm
8120		190.0mm	234.3mm

All dimensions represent the maximum value with the gripper in an OPEN configuration. Dimensions may vary based on finger type and position.

Machine Tending – S180 Parallel and Concentric Gripper Kits

S180 Kit Features:

- Gimatic DH or TH self-centering, pneumatic gripper at an 90° mounting configuration.
- Two-Jaw kits include aluminum jaws, and HNBR & rubber pad options. They feature a reversible finger base for increased gripping range.
- Three-Jaw kits include dual-sided gripper fingers to accommodate a larger variety of grip ranges.
- Both kits can be used to pick either external (closed grip) or interior surfaces (open grip).
- Two-Jaw grippers can be mounted in multiple 90° orientations.
- Three-Jaw grippers can be mounted in multiple 90° orientations.
- See EMI website for more information on DH & TH grippers.

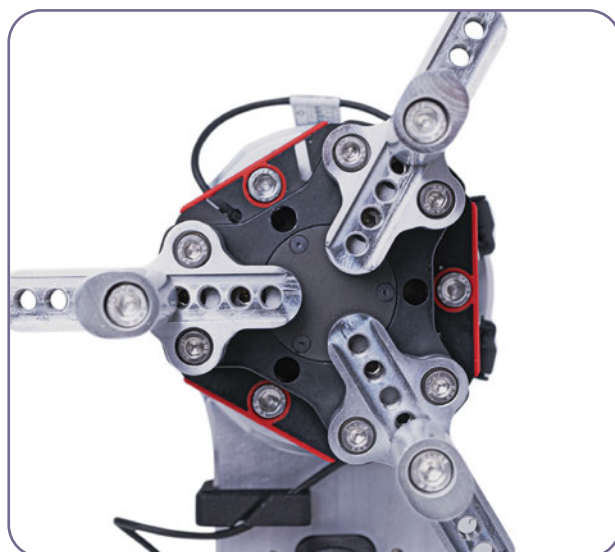
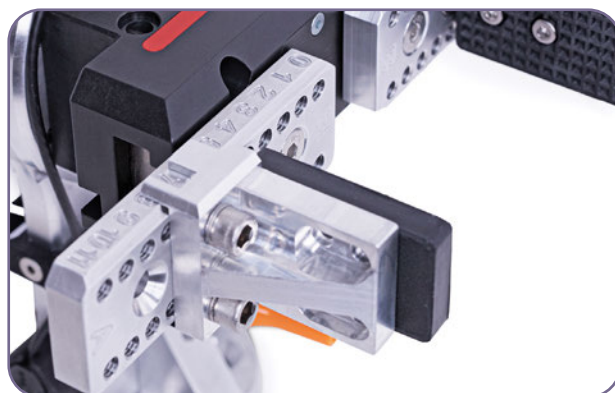

Quick#	8115	8116	8121	8122
Part#	CRK-DH4410-S180-A	CRK-DH4420-S180-A	CRK-TH5404-S180-A	CRK-TH5408-S180-A
Price	\$1,945.00	\$1,945.00	\$1,995.00	\$1,995.00
Mount configuration				
Operating pressure range	36–116 psi			
Gripper stroke	2x5mm	2x10mm	3x4mm	3x8mm
Gripper type	1x DH4410	1x DH4420	1x TH5404	1x TH5408
Closing force w/stock jaws	247.3 lbf	123.6 lbf	370.9 lbf	185.5 lbf
Kit Operating Grip Range*^	0–160mm	0–170mm	0–150mm	0–158mm
Maximum work piece mass***^	6.2 kg	3.0 kg	8.9 kg	4.4 kg
Weight	1.89 kg	1.87 kg	1.87 kg	1.87 kg

*Minimum to maximum external grip range with the included stock finger kit.

**Indicates usage at 87psi with stock finger kit with dry & clear surface conditions. Varies based on grip style, orientation, materials and input pressure.

^ Values may vary based on certain application conditions. See online product page for more detailed information.

Machine Tending – S180 Parallel and Concentric Gripper Kits

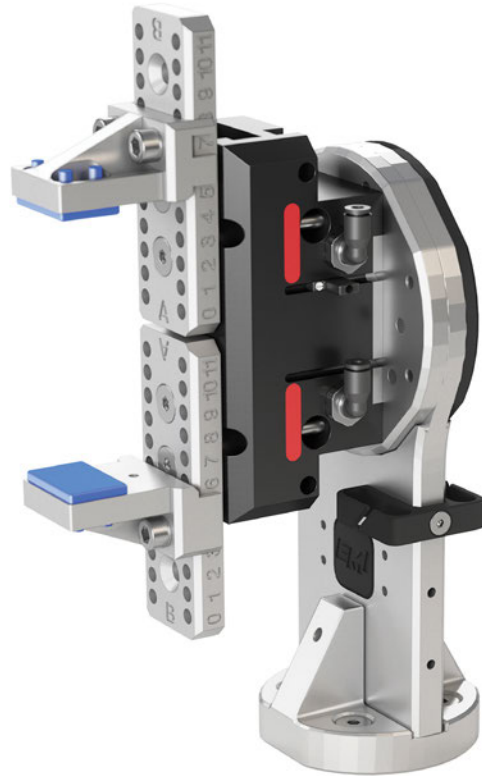

- CU
- QC
- VG
- VC
- VA
- SG
- GR
- MT**
- AC
- CS
- CC

Grippers can be mounted horizontally or vertically.



Machine Tending – 2-Jaw S-180 Parallel Gripper Kits

Quick#'s 8115 & 8116 Dimensions

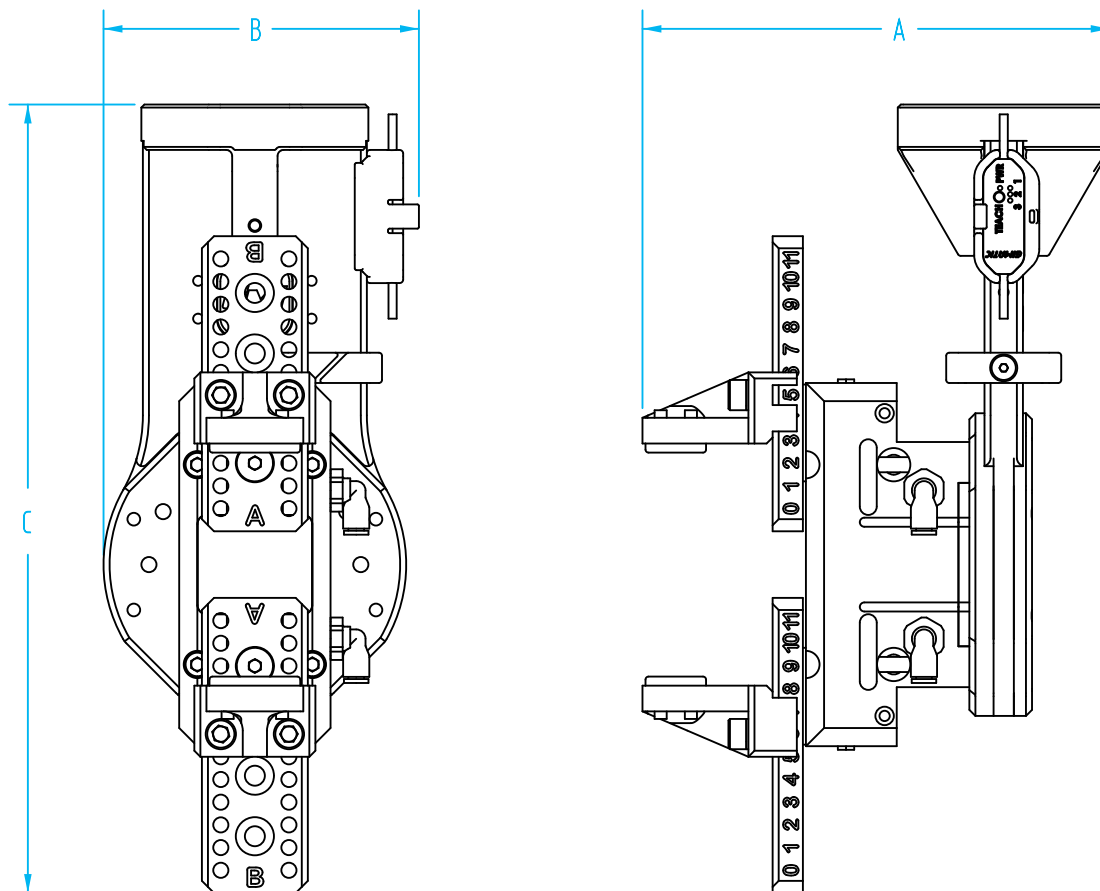

Horizontal Gripper Orientation

Quick#	A (Width)	B (Depth)	C (Height)
8115	163.4mm	104.2mm	253.8mm
8116	163.4mm	104.2mm	258.8mm

Vertical Gripper Orientation

Quick#	A (Width)	B (Depth)	C (Height)
8115	163.4mm	214.5mm	196.5mm
8116	163.4mm	224.5mm	196.5mm

All dimensions represent the maximum value with the gripper in an OPEN configuration.
Dimensions may vary based on finger type and position.

Machine Tending – 3-Jaw S180 Concentric Gripper Kits

Quick#'s 8121 & 8122 Dimensions

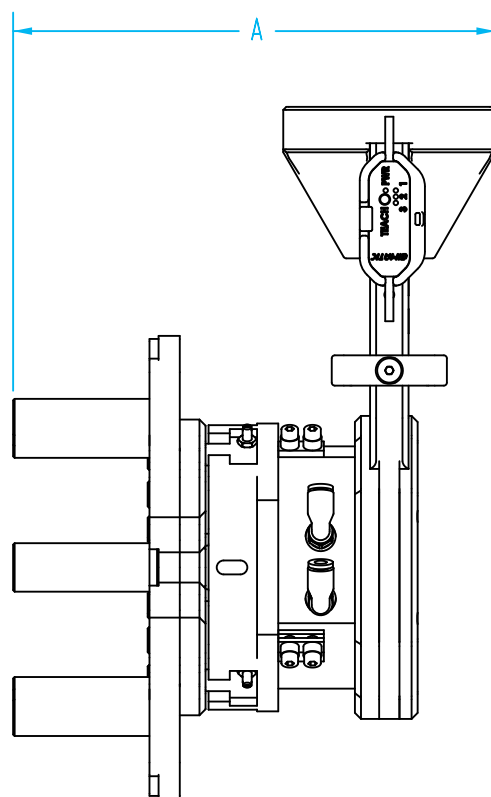
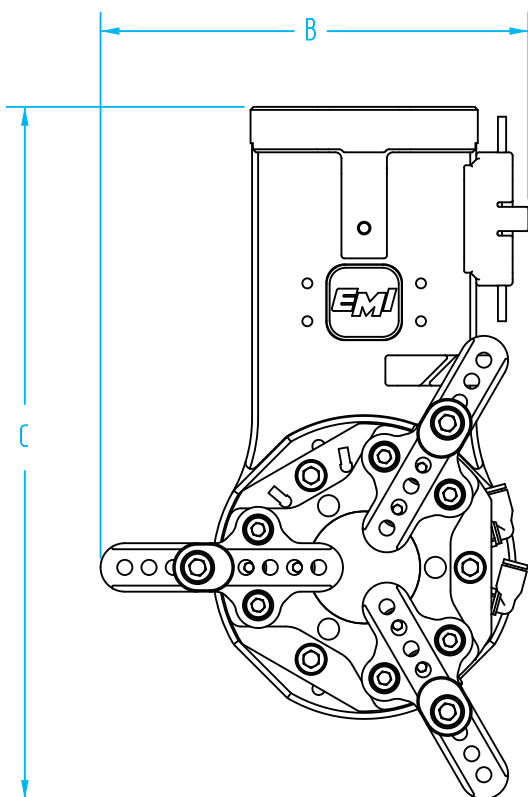

Horizontal Gripper Orientation

Quick#	A (Width)	B (Depth)	C (Height)
8121	159.2mm	157.6mm	243.0mm
8122		164.5mm	247.0mm

Vertical Gripper Orientation

Quick#	A (Width)	B (Depth)	C (Height)
8121	159.2mm	145.2mm	230.8mm
8122		149.2mm	234.3mm

All dimensions represent the maximum value with the gripper in an OPEN configuration.
Dimensions may vary based on finger type and position.

- CU
- QC
- VG
- VC
- VA
- SG
- GR
- MT**
- AC
- CS
- CC

Machine Tending – Accessories

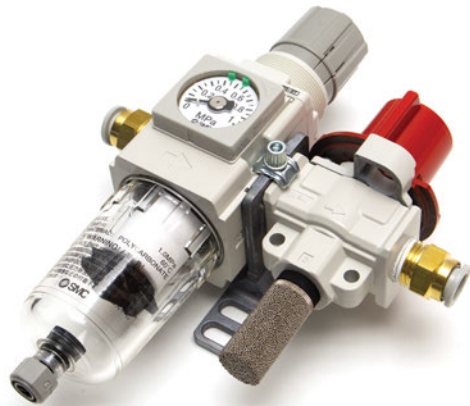

Filter / Regulator Assembly

Quick#	Part#	Description	Price
2800	CRA-FR-R14-1	Filter / Regulator with Shut-off and R1/4" Ports, Ø8mm fittings	\$99.50

- Purchase the complete kits below or the components individually and build yourself.
- Other configurations available upon request.

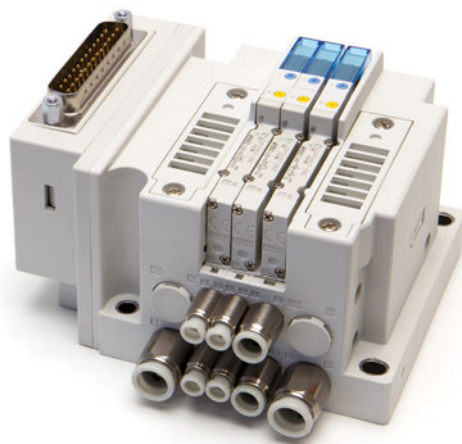

3-Station JSY1000 Valve Assembly

Quick#	Part#	Description	Price
2801	CRA-JSY1-P3Z-1	2x 5/2 Single Solenoid + 1x 5/4 Double Solenoid, PNP	\$635.00
2802	CRA-JSY1-P3Z-2	2x 5/2 Double Solenoid + 1x 5/4 Double Solenoid, PNP	\$695.00
2803	CRA-JSY1-N3Z-1	2x 5/2 Single Solenoid + 1x 5/4 Double Solenoid, NPN	\$635.00
2804	CRA-JSY1-N3Z-2	2x 5/2 Double Solenoid + 1x 5/4 Double Solenoid, NPN	\$695.00

Features:

- Filter regulator with embedded pressure gauge. A combination filter and regulator, minimizing space and piping by integrating two units into one.
- Maximum operating pressure: 145psi.
- Output pressure range: 7–125psi.
- Nominal filtration rating: 5µm.
- Pressure relief valve included with safety locking holes.
- Includes mounting bracket.
- See website for dimensional information.

Detailed view online with Valve Assembly contents:



Note: #8 (x3) Blocking disks are assembled in valve manifold stack, shown loose for reference. Disks assembled in place between manifold zone 2 and 3 to split supply pressure and exhaust to either side.

Parts for 2801 JSY1000 Valve Manifold PNP 3-Station 2-Position Single Solenoid

Enter the quantity for each needed part and click add to cart

No.	Part No.	Item Description	Qty Req.	Price	Qty
1	JSY11M 1P 3A51 CB	2815 JSY1000 Manifold Block	1	\$39.65 Each	
2	JSY11M 3P 1A5 CB	2816 JSY1000 Manifold Block	1	\$16.00 Each	
3	JSY11M 2P 1DA C4	2821 6.5mm Pitch Manifold Base with 4mm Fittings	2	\$13.40 Each	
4	JSY11M 2P 2DA C6	2822 9mm Pitch Manifold Base	1	\$13.40 Each	
5	JSY1100T 5NZ	2827 Single Solenoid Valve 2 Position-PNP	2	\$45.00 Each	
6	JSY1A00T 5NZ	2833 Double Solenoid Valve 4 Position Dual 3 Port-PNP	1	\$71.80 Each	
7	JSY11M 26P 1A	2835 Blanking Plate for JSY1000 Valve Manifold	1	\$4.40 Each	
8	JSY11M 40P 1A	2875 Supply/Exhaust Blocking Disk (1pc)	3	\$2.10 Each	
9	SJ3000 155 1A	2876 Supply/Exhaust Blocking Disk LABEL (1pc)	1	\$11.30 Each	
10	AXT100 DS25 030	2908 25-Pin D-Sub Cable -3m	1	\$95.80 Each	
11	EL 704W	5073 Din Rail 1M	1	\$18.92 Each	
12	GSF QP 04	192 Plug Fitting For #4mm Tube	4	\$0.40 Each	
13	GSF QP 06	193 Plug Fitting For #6mm Tube	2	\$1.00 Each	
14	JSY11M 15P 1A	2909 Din Rail Bracket	2	\$10.30 Each	
15	GSC MS LW SS	M5 Lock Washer	6	\$0.20 Each	
16	GSC MS 20 SS	M5x20mm SHCS-Stainless Steel	4	\$0.50 Each	
17	GSC MS FW	868 M5 Fender Washer	2	\$0.10 Each	
18	GSC MS 8 SS	M5x8mm SHCS-Stainless	2	\$0.40 Each	
19	CRA CMK 1	8015 Cable Management Kit for Collaborative Robots	2	\$35.00 Each	
20	GSF QTU 08	149 8mm Push-In T Fitting	1	\$4.90 Each	
21	GSU PB 0424	960 4mm Blue Polyurethane Tubing - 25' Coil	1	\$5.68 Each	
22	GSU PR 0424	966 4mm Red Polyurethane Tubing - 25' Coil	1	\$5.68 Each	
23	GSU PB 0604	961 6mm Blue Polyurethane Tubing - 25' Coil	1	\$9.38 Each	
24	GSU PB 0806	962 8mm Blue Polyurethane Tubing - 25' Coil	1	\$16.37 Each	

Enter the quantity for each needed part and click add to cart

**In-Stock
Replacement Parts**



Gimatic 2-Jaw DH44.. Finger Kit

Quick#	Part#	Description	Price
8131	CRA-DH44-FK1	Aluminum jaws, and HNBR & rubber pad options, along with the mounting plate and hardware.	\$174.95



Gimatic 2-Jaw TH54.. Finger Kit

Quick#	Part#	Description	Price
8132	CRA-TH54-FK1	Dual-sided gripper fingers to accommodate a larger variety of grip ranges, along with the mounting plate and hardware.	\$239.95



Machine Tending Blow-Off Kit

Quick#	Part#	Description	Price
8130	CRA-LLBO-1	Loc-Line® Blow-Off Kit	\$34.95

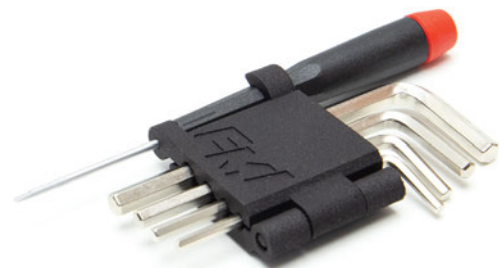

Machine Tending Toolkit with Magnet

Quick#	Part#	Description	Price
8110	CRA-TOOLKIT-1	2.5 – 5mm Hex Wrench and 1.8 PFHSD	\$22.95

- CU
- QC
- VG
- VC
- VA
- SG
- GR
- MT**
- AC
- CS
- CC

SCHUNK PGN-plus-P – 2-Jaw Gripper for Machine Tending

EMI's Machine Tending Kits are now available with one of the industry's most iconic gripper, the PGN-plus-P self centering, 2-jaw parallel gripper by SCHUNK.

Compatible with EMI's existing mounting interface and adjustable gripper fingers, the PGN series gripper is a fantastic compliment to EMI's product offering.

- 2-jaw, self centering parallel gripper.
- Precision ground guidance for high repeatability.
- Lubrication pockets integrated into the jaws for maximum service life.
- High grip force and safety load rating.
- Protection class: IP40.
- Integrated positive pressure port for increased protection.
- Sensor ready housing.
- Dust proof cover accessory available for increased protection.

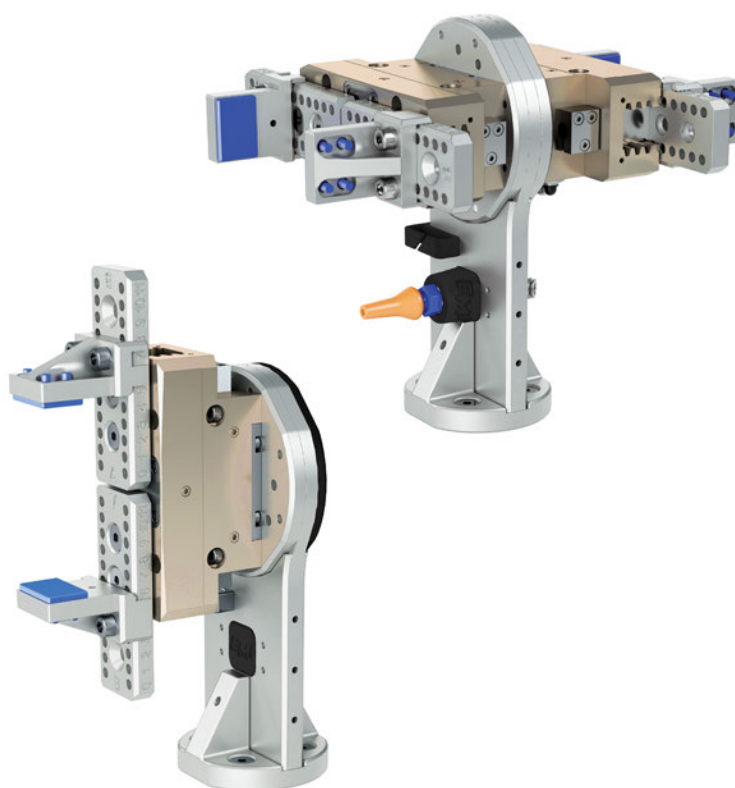
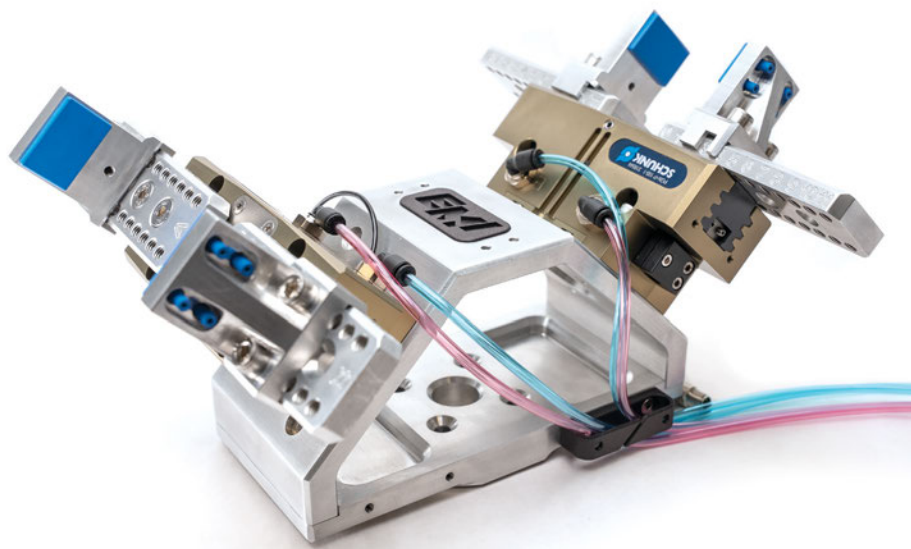

SCHUNK PZN-plus – 3-Jaw Gripper for Machine Tending

Elevate your 3-jaw, concentric style parallel gripper Machine Tending Kit by EMI with the PZN-plus gripper series. Contact EMI for both existing and new applications!

Known for its precision and robustness, the PZN series gripper by SCHUNK is a great fit for loading and unloading parts out of mills and lathes.

- 3-jaw concentric, parallel gripper.
- Precision guidance for high repeatability.
- High grip force and safety load rating.
- Protection class: IP40.
- Sensor ready housing.
- Dust proof cover accessory available for increased protection.

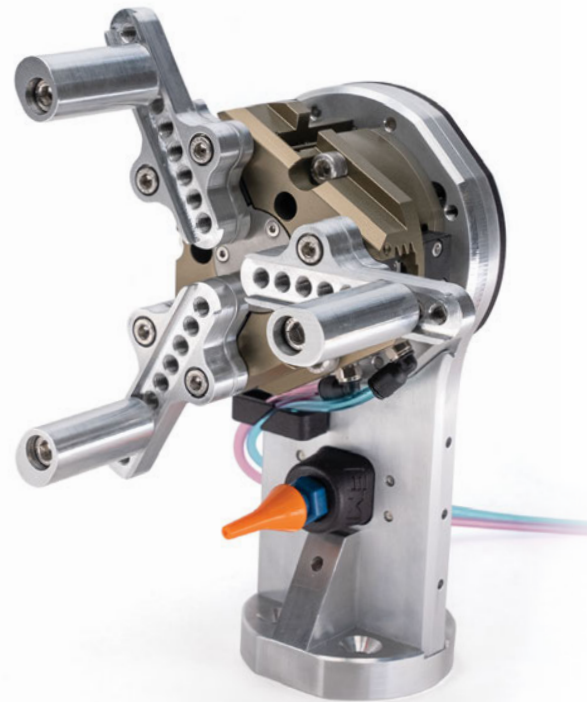

- CU
- QC
- VG
- VC
- VA
- SG
- GR
- MT**
- AC
- CS
- CC

