

Parallel Gripper for Cobots – OnRobot 2FG7 & 2FG14

OnRobot 2FG7 & 2FG14 are a complete, off-the-shelf electric parallel gripper that can be deployed within minutes and require no custom engineering for installation or maintenance.

These strong parallel grippers can be used in tight spaces and handle demanding payload requirements.



Quick# 8204
Part# OR-106376
PRICE: \$4,633.00

Quick# 8206
Part# OR-114000
PRICE: \$5,112.00

OnRobot pricing effective 05/01/24 and subject to change.

- Grip detection / lost grip detection.
- Integrated software.
- Ready for use almost anywhere, with IP67 rating for harsh environments and ISO Class 5 certification for cleanroom use.

Try It Risk Free!

*Contact us for details



Technical Specs	8204 - 2FG7	8206 - 2FG14
Total OD stroke with fingers inwards	1–39mm	5–55mm
Total OD stroke with fingers outwards	35–73mm	55–105mm
Total ID stroke with fingers inwards	11–49mm	17.6–67.6mm
Total ID stroke with fingers outwards	45–83mm	67.6–117.6mm
Payload with stock fingers (force fit)	15.43 lb (7kg)	30.86 lb (14kg)
Payload with custom fingers (form fit)	24.25 lb (11kg)	44.09 lb (20kg)
Repetition accuracy	± 0.1mm	
Gripping force (adjustable)*	20 – 140 N (4.5 – 31.5 lbf)	40 – 280 N (9 – 63 lbf)
Gripping force deviation	+/- 5%	+/- 10%
Gripping speed**	16mm – 450mm /second	16mm – 100mm /second
Gripping time***	200ms	
Storage temperature	32° – 140°F	
Weight	1100g (2.4 lb)	1450g (3.2 lb)
Power supply	20V – 25V	
Max. Current consumption****	2000mA	
Operating temperature	41° – 122°F	

* The required current is 2000 mA, less current will result in less gripping force.
 ** Relatively from the gripping object (both arms).
 *** At 4 mm stroke and 80 N. The typical value is 300 ms at 40 mm and 80 N.
 ****Automatically adapts to the current requirements when UR CB3 tool connector is used (600mA).

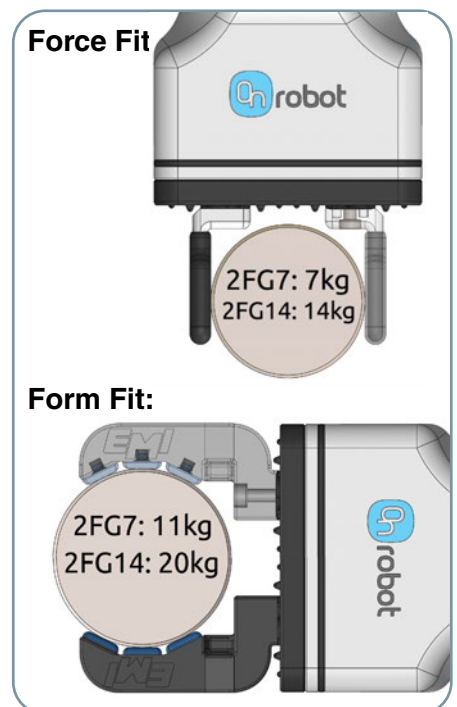



Parallel Gripper for Cobots – OnRobot 2FG7 & 2FG14

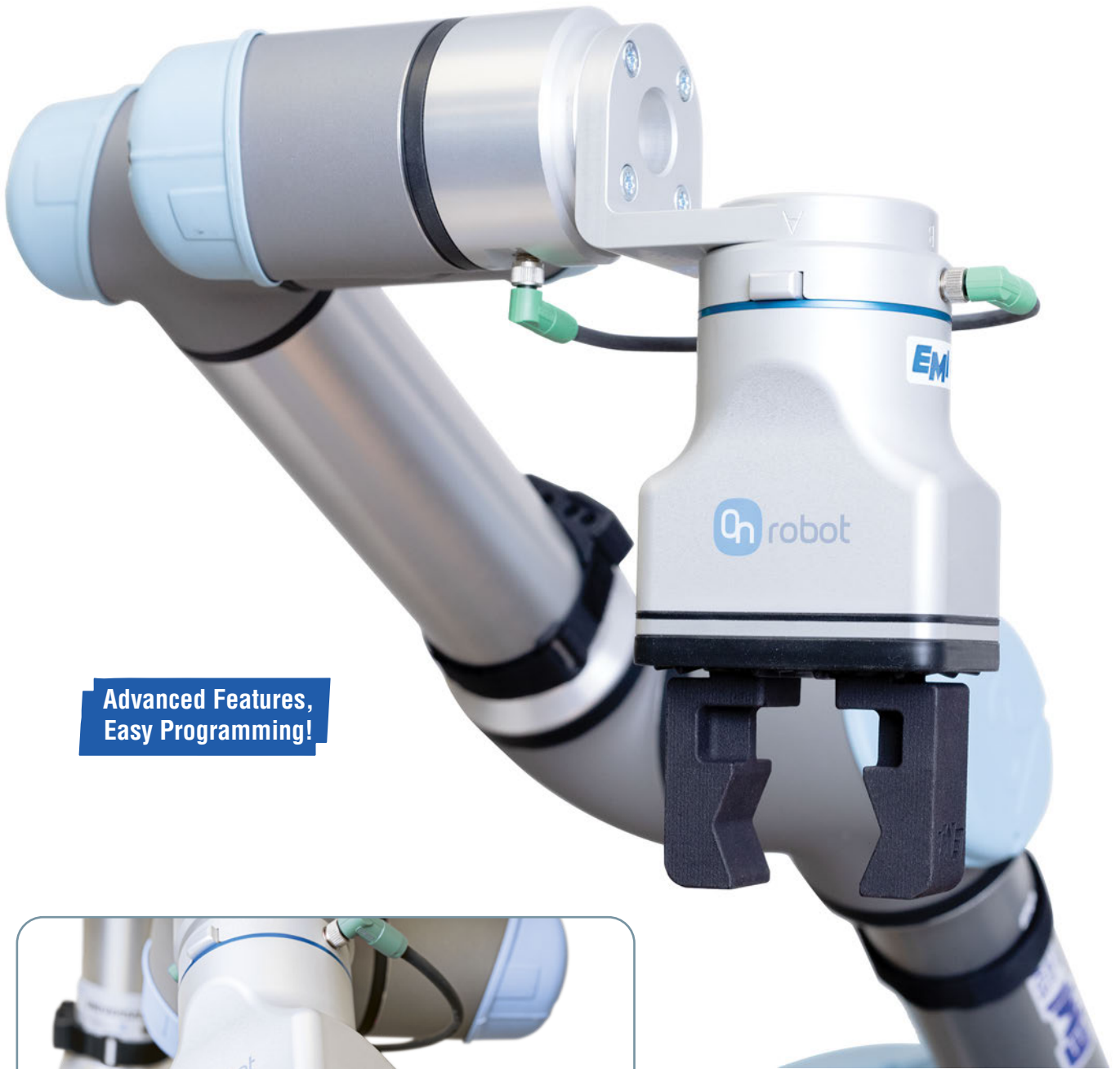

- CU
- QC
- VG
- VC
- VA
- SG
- GR**
- MT
- AC
- CS
- CC

**Advanced Features,
Easy Programming!**



Shown with 3D printed fingers available from EMI.

Parallel Gripper for Cobots – OnRobot 2FG7 & 2FG14

(Dimensioned drawing #8204 shown full scale)

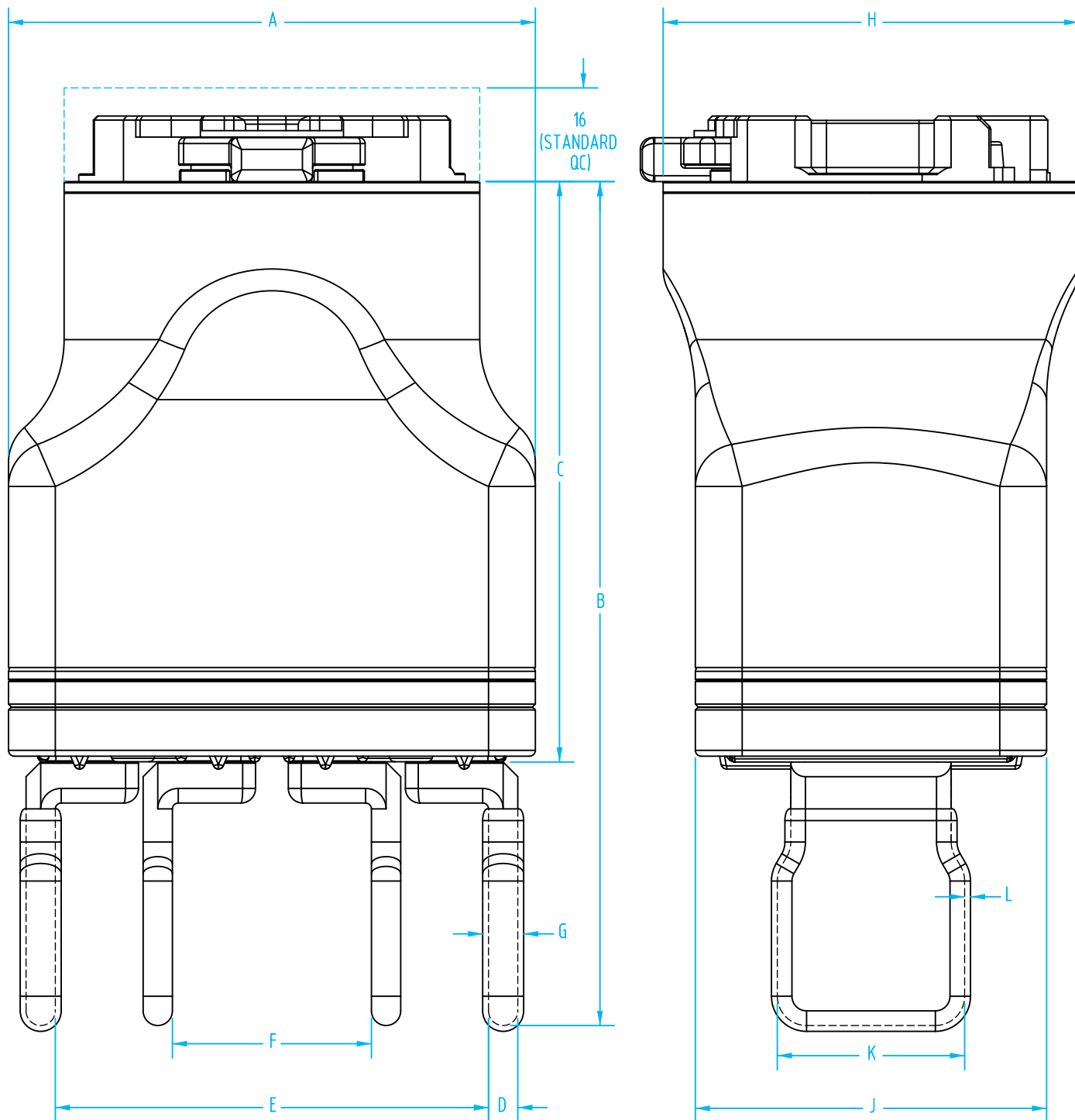

Quick#	A	B	C	D	E	F	G	HØ	J	K	L
8204	90	144	99	5	74	34	7	71	60	32	1
8206	115	155.2	103.2	-	105	55	6.3	71	70	45	-



Parallel Gripper for Cobots – OnRobot 2FG7 & 2FG14

(Dimensioned drawing shown full scale)

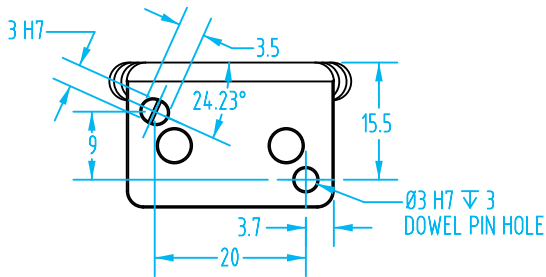
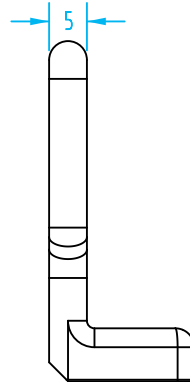
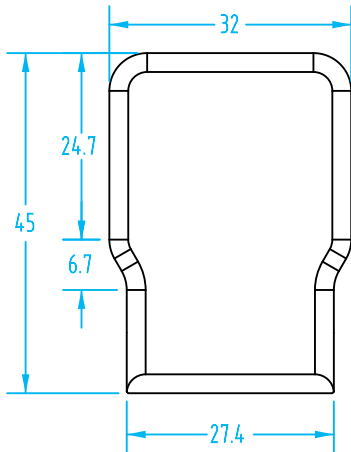
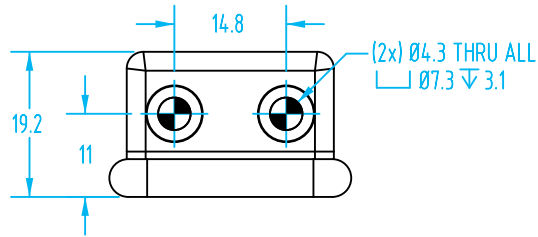

**In-Stock
Replacement Parts!**



- CU
- QC
- VG
- VC
- VA
- SG
- GR**
- MT
- AC
- CS
- CC

Replacement 2FG7 Parts

Quick#	Part#	Description	Price
8295	OR-106553	2-Finger Kit (2pc plus hardware)	\$223.33
8296	OR-106559	Finger Sleeves (4pc)	\$86.67
8297	OR-113012	Bellow Kit (2pc)	\$53.33

Contact EMI for 2FG14 replacement parts or shop online!

Use Quick#s for easy online ordering.