

# PZN-plus 125

Universal gripper

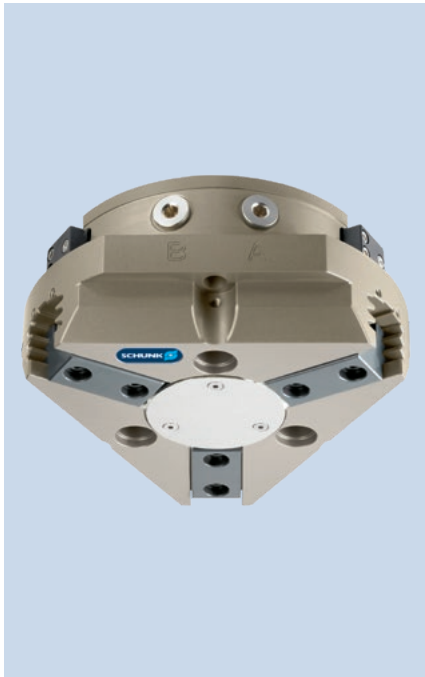

## Gripping force O.D. gripping

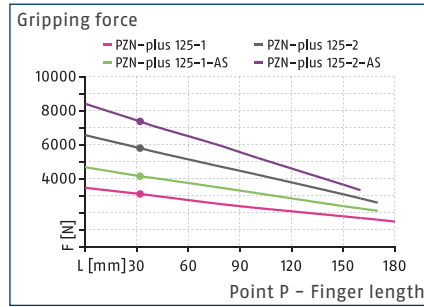

## Gripping force I.D. gripping

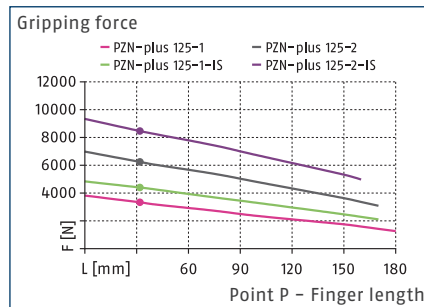

## Dimensions and maximum loads

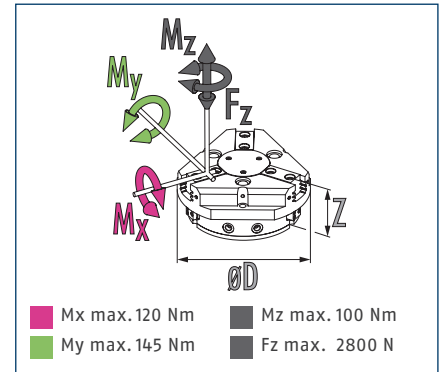

① The indicated moments and forces are static values, apply for each base jaw and may appear simultaneously. Loads may additionally occur to the moment produced by the gripping force itself.

## Technical data

Description		PZN-plus 125-1	PZN-plus 125-2	PZN-plus 125-1-AS	PZN-plus 125-2-AS	PZN-plus 125-1-IS	PZN-plus 125-2-IS
ID		0303313	0303413	0303513	0303613	0303543	0303643
Stroke per jaw	[mm]	13	6	13	6	13	6
Closing/opening force	[N]	3100/3330	5800/6240	4150/-	7970/-	-/4400	-/8450
Min. spring force	[N]			1050	2170	1070	2210
Weight	[kg]	2.47	2.47	3.34	3.34	3.34	3.34
Recommended workpiece weight	[kg]	15.5	29	15.5	29	15.5	29
Cylinder volume per double stroke	[cm <sup>3</sup> ]	230	230	383	383	383	383
Min./nom./max. operating pressure	[bar]	2/6/8	2/6/8	4/6/6.5	4/6/6.5	4/6/6.5	4/6/6.5
Min./max. air purge pressure	[bar]	0.5/1	0.5/1	0.5/1	0.5/1	0.5/1	0.5/1
Closing/opening time	[s]	0.2/0.2	0.2/0.2	0.17/0.35	0.17/0.35	0.35/0.17	0.35/0.17
Closing/opening time with spring	[s]			0.40	0.40	0.40	0.40
Max. permissible finger length	[mm]	180	170	170	160	170	160
Max. permissible weight per finger	[kg]	2.1	2.1	2.1	2.1	2.1	2.1
IP protection class		40	40	40	40	40	40
Min./max. ambient temperature	[°C]	5/90	5/90	5/90	5/90	5/90	5/90
Repeat accuracy	[mm]	0.01	0.01	0.01	0.01	0.01	0.01
Dimensions Ø D x Z	[mm]	150 x 67	150 x 67	150 x 91.5	150 x 91.5	150 x 91.5	150 x 91.5
<b>Options and their characteristics</b>							
Dustproof version		37303313	37303413	37303513	37303613	37303543	37303643
IP protection class		64	64	64	64	64	64
Weight	[kg]	2.9	2.9	3.7	3.7	3.7	3.7
Corrosion-protected version		38303313	38303413	38303513	38303613	38303543	38303643
High-temperature version		39303313	39303413	39303513	39303613	39303543	39303643
Min./max. ambient temperature	[°C]	5/130	5/130	5/130	5/130	5/130	5/130
Power booster version		0372204	0372214	0372224		0372244	
Closing/opening force	[N]	5209/5450	9674/10489	6097/-		-/6565	
Weight	[kg]	3.7	3.7	4.5		4.5	
Maximum pressure	[bar]	6	6	6		6	
Max. permissible finger length	[mm]	125	100	100		100	
Precision version		0303343	0303443	0303493	0303593		

① It may take a few 100 gripping cycles until the full gripping force (as indicated in the data table) will be available.

## Main view

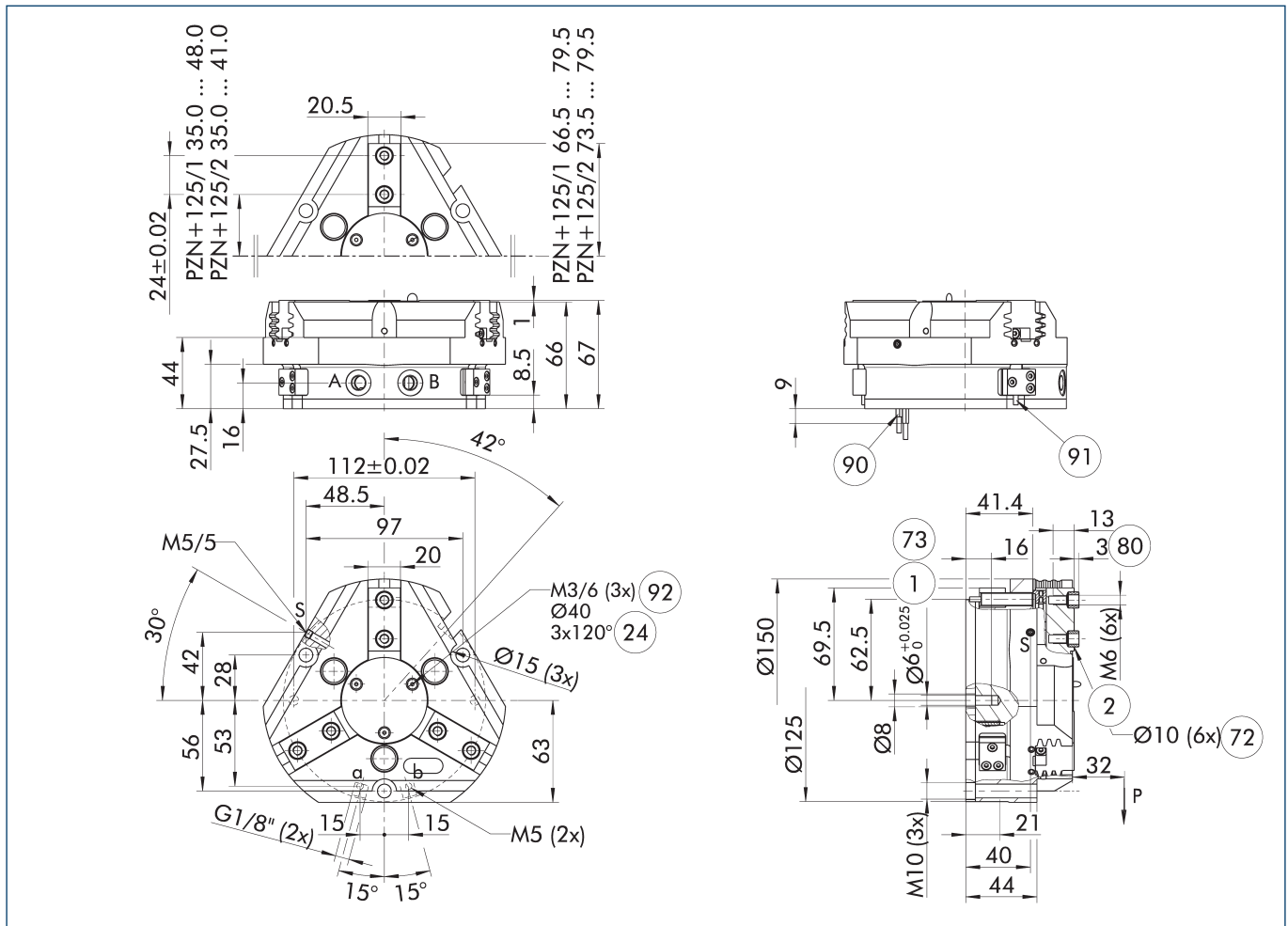

The drawing shows the gripper in the basic version with closed jaws, without dimensional consideration of the options described below.

① As an alternative/in addition to spring-assisted mechanical gripping force maintenance, the SDV-P pressure maintenance valve can be used for I.D. and O.D. gripping (see "Accessories" section of catalog).

- A, a Main / direct connection, gripper opening
- B, b Main / direct connection, gripper closing
- S Air purge connection
- ① Gripper connection
- ② Finger connection
- ②④ Bolt circle
- ⑦② Fit for centering sleeves
- ⑦③ Fit for centering pins
- ⑧⑩ Depth of the centering sleeve hole in the counter part
- ⑨⑩ Sensor MMS 22..
- ⑨① Sensor IN ...
- ⑨② Thread below the cover for fastening external attachments

# PZN-plus 125

Universal gripper

## Hose-free direct connection M5

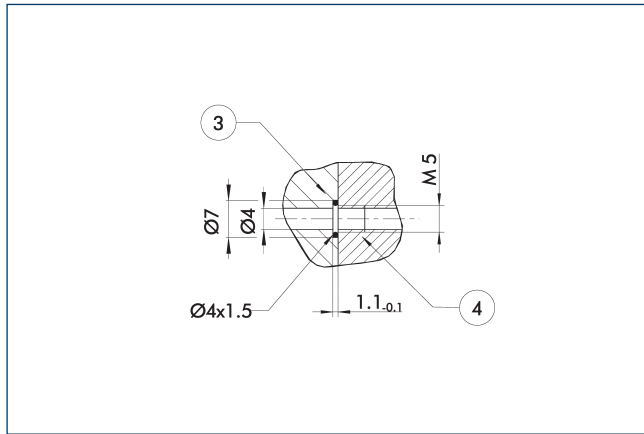

- ③ Adapter
- ④ Grippers

The direct connection is used for supplying compressed air without hoses. Instead, the pressure medium is fed through bore-holes in the mounting plate.

## Gripping force maintenance version AS/IS

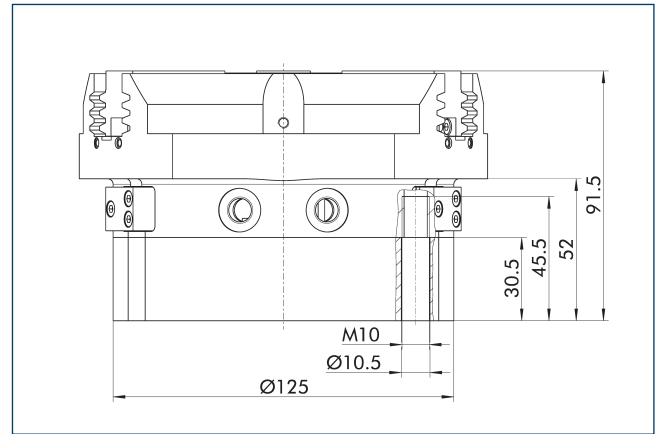

The mechanical gripping force maintenance device ensures that a minimum clamping force will be applied even if there is a drop in pressure. In the AS/IS variant this acts as a closing force, in the IS variant as an opening force. Besides this, gripping force maintenance can be used to increase gripping force or for single actuated gripping.

## Dustproof version

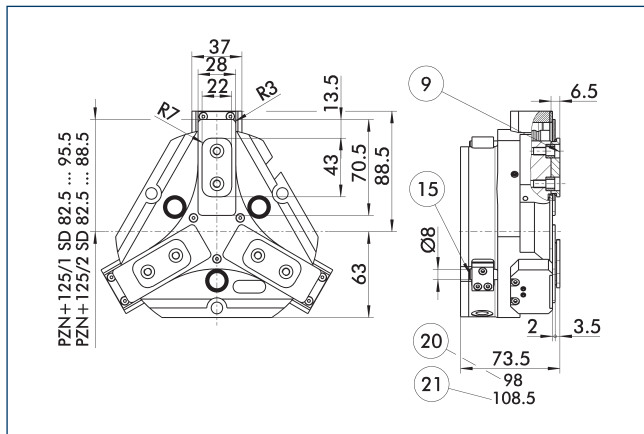

- ⑨ For mounting screw connection
- ⑩ For version AS/IS diagram, see basic version
- ⑮ Sealing bolt
- ⑳ Applies for KVZ version

The "dustproof" option increases the degree of protection against penetrating substances. The assembly diagram shifts by the height of the intermediate jaw. The finger length is still measured from the upper edge of the gripper housing.

## Power booster version

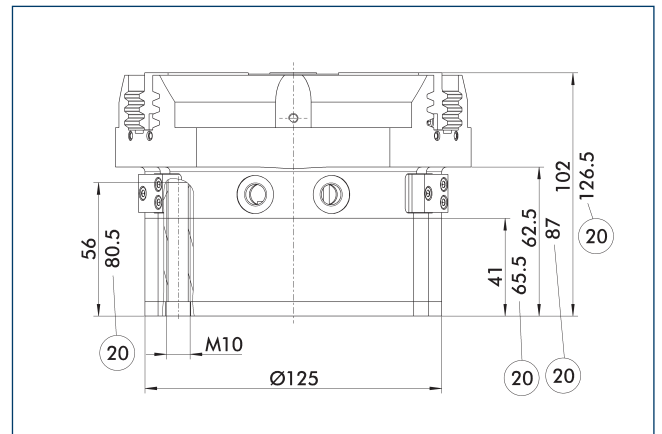

- ⑳ For version AS/IS

The KVZ cylinder increases the gripping forces during opening and closing. A second, in series-connected piston also increases the force on the wedge hook. Please consider that grippers which are equipped with a gripping force maintenance device are higher.

## Precision version

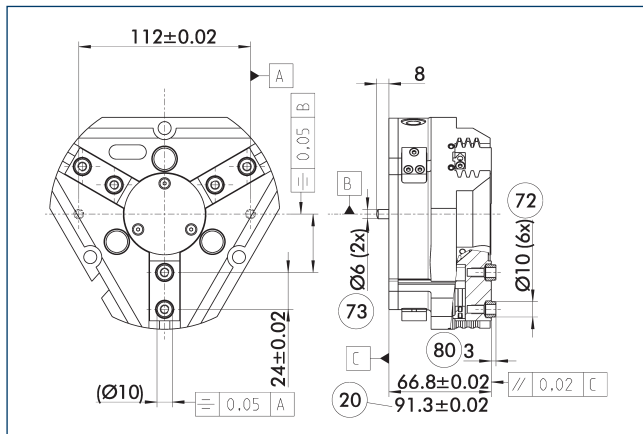

- ②0 For version AS/IS
- ⑦2 Fit for centering sleeves
- ⑦3 Fit for centering pins
- ⑧0 Depth of the centering sleeve hole in the counter part

The indicated tolerances just refer to the variants of precision versions shown in the chart of technical specifications. All other variants of precision versions are available on request.

## Spring-loaded pressure piece

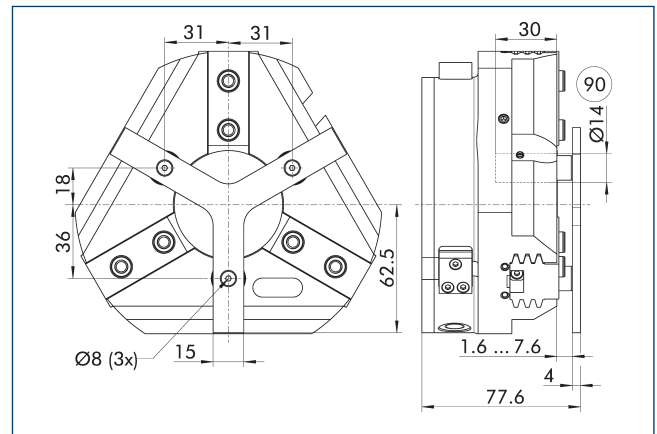

- ⑨0 Guide pin

For spring-supported positioning of the workpiece against a stop after the gripper has opened. Especially developed for loading machines.

Description	ID	Stroke [mm]	Min. force [N]
Spring-loaded pressure piece			
A-PZN-plus/DPZ-plus 125	0303723	6	105

- ① The pressure piece cannot be combined with the dustproof option. Please contact us if you require a customized pressure piece.

## SDV-P pressure maintenance valve

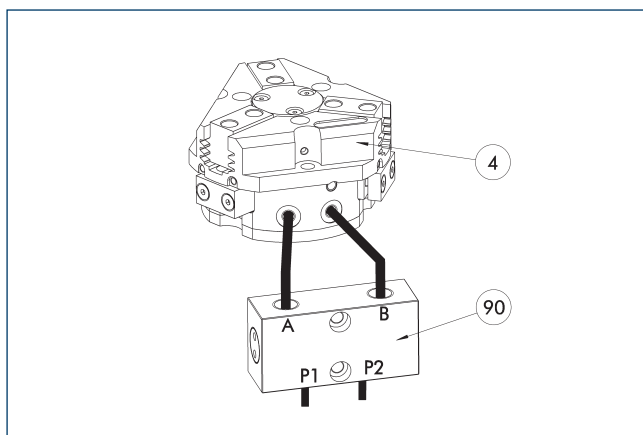

- ④ Grippers
- ⑨0 SDV-P pressure maintenance valve

The SDV-P pressure maintenance valve ensures in emergency STOP situations that the pressure in the piston chamber of pneumatic gripper, swivel, linear, and quick-change modules is temporarily maintained.

Description	ID	Recommended hose diameter [mm]
Pressure maintenance valve		
SDV-P 07	0403131	8
Pressure maintenance valve with air bleed screw		
SDV-P 07-E	0300121	8

- ① In order to achieve the specified closing and opening time for each gripper variant, the recommended hose diameter must be used. The direct allocation of the respective variant of the gripper for the respective SDV-P can be found at schunk.com.

## Pneumatic positioning device PPD

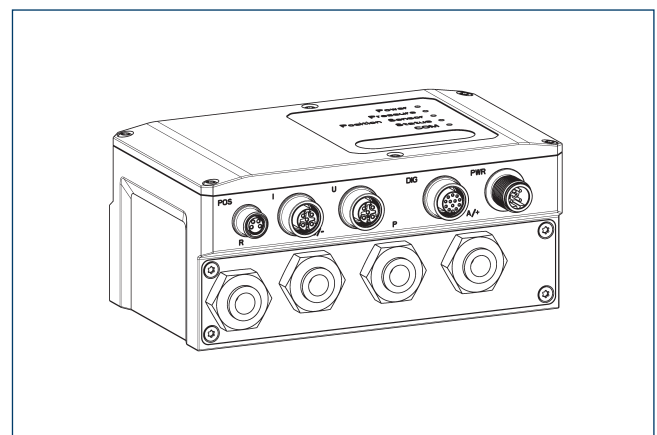

The PPD allows flexibility in all applications with pneumatic grippers through free positioning, gripping force and speed adjustment.

Description	ID	
Pneumatic positioning device		
PPD 20-IOL	1540700	
Adapter		
A GGN0804-1204-A	1540691	
IO-Link connection cable		
KA GGN1205-1212-IOL-00100-A	1540697	
Voltage supply connection cable - cable track compatible		
KA GLN12B05-LK-01000-A	1540660	
Cable extension		
KV GGN0804-I0-00150-A	1540662	
KV GGN0804-I0-00300-A	1540663	
Assembly set		
Assembly set PPD	1540705	

- ① In addition to the PPD, a position sensor (SCHUNK IO-Link sensor or analog sensor (4...20 mA)) is required.

# PZN-plus 125

Universal gripper

## Protective cover HUE PZN-plus 125

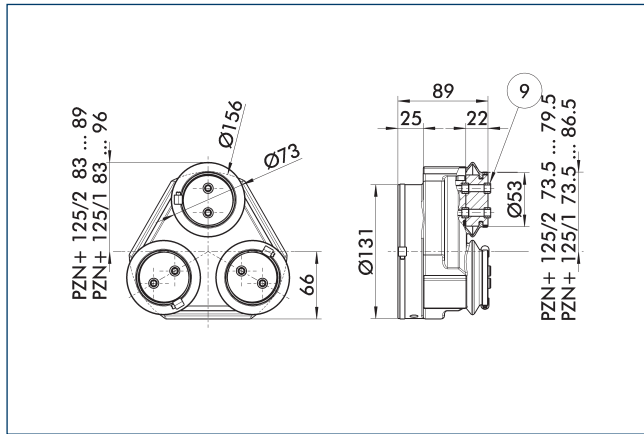

⑨ For mounting screw connection diagram, see basic version

The HUE protective cover fully protects the gripper against external influences. The cover is suitable for applications of up to IP65 if an additional sealing of the cover bottom is provided. For detailed information, please see the HUE series. The connection diagram shifts by the height of the intermediate jaw.

Description	ID	IP protection class
Protection cover		
HUE PZN-plus 125	0303483	65

① An inductive monitoring of the gripper in connection with the protective cover HUE is not possible. SCHUNK recommends the use of magnetic sensors that are approved for the respective gripper version.

## BSWS jaw quick-change jaw systems

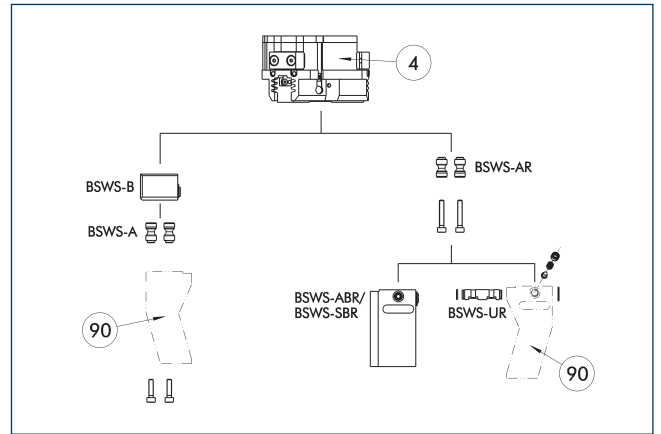

④ Grippers

⑨ Customized gripper fingers

There are various jaw quick-change systems available for the gripper. For detailed information, please refer to the corresponding product.

Description	ID	Scope of delivery
Jaw quick-change system adapter pin		
BSWS-A 125	0303028	2
BSWS-AR 125	0300095	2
Quick-change jaw system base		
BSWS-B 125	0303029	1
Jaw quick-change system finger blank		
BSWS-ABR-PGZN-plus 125	0300075	1
BSWS-SBR-PGZN-plus 125	0300085	1
Jaw quick-change system locking mechanism		
BSWS-UR 125	0302994	1

① If the operating pressure is higher than 6 bar, suitability for use beyond the application limits must be checked. Only systems that are listed in the table, can be used.

### Fields of application

Series	Size	Variant	Suitability
PZN-plus	125	-1 (6 bar)	■■■■■
PZN-plus	125	-1-AS/1-IS (6 bar)	■■■■■
PZN-plus	125	-2 (6 bar)	■■■■■
PZN-plus	125	-2-AS/2-IS (6 bar)	■■■□□
PZN-plus	125	-...-KVZ (6 bar)	■■■□□
Legend			
■■■■■	Can be combined without restrictions		
■■■□□	Use with restrictions (see loading limits)		
□□□□□	cannot be combined		

The load limits for describing the application limits can be found in the catalog chapter of the corresponding accessories.

## Jaw quick-change system BSWS-M

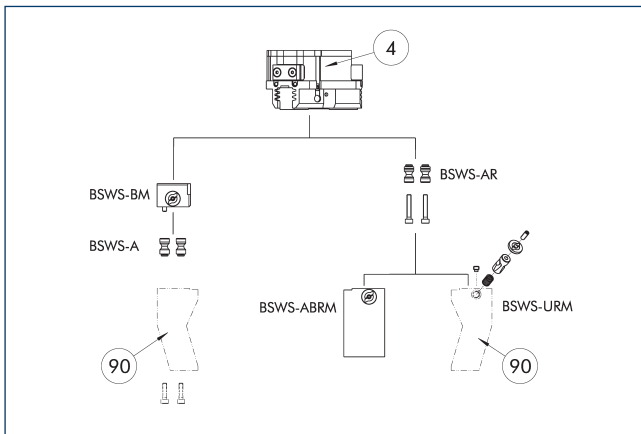

④ Grippers

⑨ Customized gripper fingers

There are various jaw quick-change systems available for the gripper. For detailed information, please refer to the corresponding product.

Description	ID	Scope of delivery
Jaw quick-change system adapter pin		
BSWS-A 125	0303028	2
BSWS-AR 125	0300095	2
Quick-change jaw system base		
BSWS-BM 125	1302006	1
Jaw quick-change system finger blank		
BSWS-ABRM-PGZN-plus 125	1420854	1
Jaw quick-change system locking mechanism		
BSWS-URM 125	1398404	1

① If the operating pressure is higher than 6 bar, suitability for use beyond the application limits must be checked. Only systems that are listed in the table, can be used.

### Fields of application

Series	Size	Variant	Suitability
PZN-plus	125	-1 (6 bar)	■■■■■
PZN-plus	125	-1-AS/1-IS (6 bar)	■■■■■
PZN-plus	125	-2 (6 bar)	■■■■■
PZN-plus	125	-2-AS/2-IS (6 bar)	■■■□□
PZN-plus	125	-...-KVZ (6 bar)	■■■□□
Legend			
■■■■■	Can be combined without restrictions		
■■■□□	Use with restrictions (see loading limits)		
□□□□	cannot be combined		

The load limits for describing the application limits can be found in the catalog chapter of the corresponding accessories.

## Jaw quick-change system BSWS-R

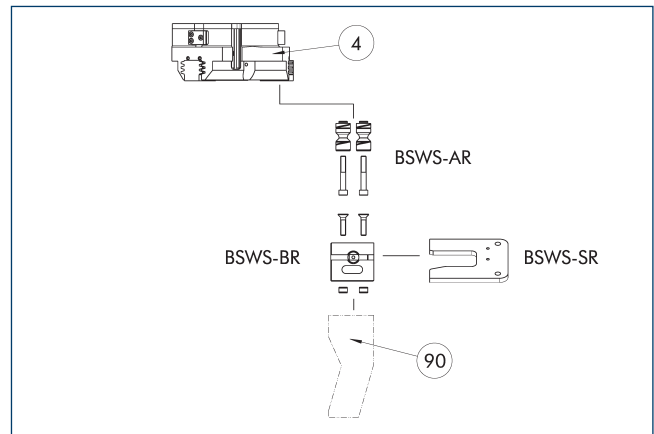

④ Grippers

⑨ Customized gripper fingers

If the operating pressure is higher than 6 bar, suitability for use beyond the application limits must be checked. Only systems that are listed in the table, can be used.

Description	ID	Scope of delivery
Jaw quick-change system adapter pin		
BSWS-AR 125	0300095	2
Quick-change jaw system base		
BSWS-BR 125	1555937	1
Storage system		
BSWS-SR 125	1555972	1
Attachment kit for proximity switch		
AS-IN80-BSWS-SR 125/160	1561467	1
Inductive proximity switches		
IN 80-S-M12	0301578	
IN 80-S-M8	0301478	
INK 80-S	0301550	

① Only systems that are listed in the table, can be used.

### Fields of application

Series	Size	Variant	Suitability
PZN-plus	125	-1 (6 bar)	■■■■■
PZN-plus	125	-1-AS/1-IS (6 bar)	■■■■■
PZN-plus	125	-2 (6 bar)	■■■■■
PZN-plus	125	-2-AS/2-IS (6 bar)	■■■□□
PZN-plus	125	-...-KVZ (6 bar)	■■■□□
Legend			
■■■■■	Can be combined without restrictions		
■■■□□	Use with restrictions (see loading limits)		
□□□□	cannot be combined		

The load limits for describing the application limits can be found in the catalog chapter of the corresponding accessories.

# PZN-plus 125

Universal gripper

## ZBA-L-plus 125 intermediate jaws

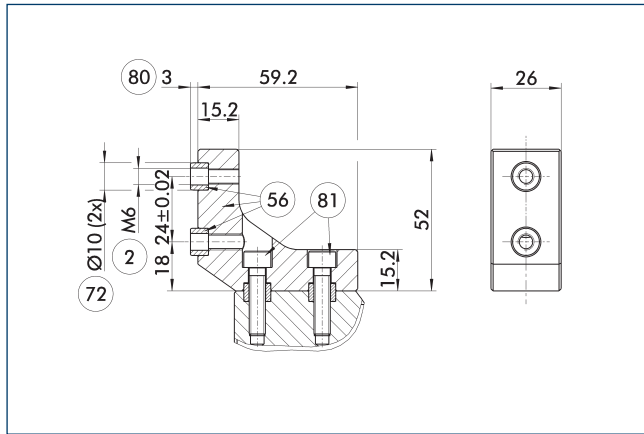

- ② Finger connection
- ⑤⑥ Included in the scope of delivery
- ⑦② Fit for centering sleeves
- ⑧① Depth of the centering sleeve hole in the counter part
- ⑧① Not included in the scope of delivery

The optional ZBA-L-plus intermediate jaws allow the screw connection diagram of the top jaws to be rotated by 90°. This makes it easier to design and produce top jaws (particularly for long versions) because no deep through-bores are required.

Description	ID	Material	Finger interface	Scope of delivery
Intermediate jaw				
ZBA-L-plus 125	0311752	Aluminum	PGN-plus 125	1

## UZB 125 universal intermediate jaw

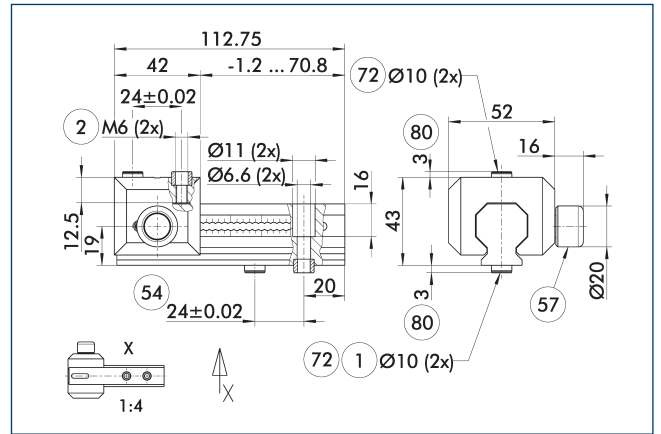

- ① Gripper connection
- ② Finger connection
- ⑤④ Optional right or left connection
- ⑤⑦ Locking
- ⑦② Fit for centering sleeves
- ⑧① Depth of the centering sleeve hole in the counter part

The drawing shows the UZB universal intermediate jaw. The fully removable UZB-S slide (can also be ordered separately) allows for a quick jaw change.

Description	ID	Grid dimension
		[mm]
Universal intermediate jaw		
UZB 125	0300045	3
Finger blank		
ABR-PGZN-plus 125	0300013	
SBR-PGZN-plus 125	0300023	
Slide for universal intermediate jaw		
UZB-S 125	5518273	3

ⓘ If the operating pressure is higher than 6 bar, suitability for use beyond the application limits must be checked.

### Fields of application

Series	Size	Variant	Suitability
PZN-plus	125	-1 (6 bar)	■■■■
PZN-plus	125	-1-AS/1-IS (6 bar)	■■□□
PZN-plus	125	-2 (6 bar)	□□□□
PZN-plus	125	-2-AS/2-IS (6 bar)	□□□□
PZN-plus	125	-...-KVZ (6 bar)	□□□□
Legend			
■■■■	Can be combined without restrictions		
■■□□	Use with restrictions (see loading limits)		
□□□□	cannot be combined		

The load limits for describing the application limits can be found in the catalog chapter of the corresponding accessories.

## Finger blanks ABR/SBR-PGZN-plus 125

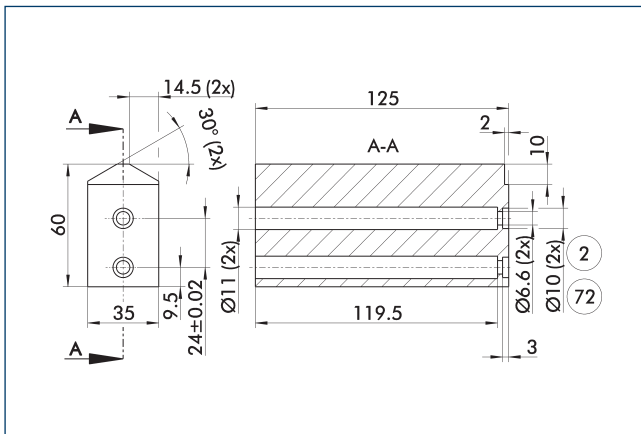

② Finger connection

⑦② Fit for centering sleeves

The drawing shows the finger blank which can be reworked by the customer.

Description	ID	Material	Scope of delivery
Finger blank			
ABR-PGZN-plus 125	0300013	Aluminum (3.4365)	1
SBR-PGZN-plus 125	0300023	Steel (1.7131)	1

① In the PGL-plus-P gripper series, the use of finger blanks results in a limitation of the closing stroke. Please check this in detail in advance using the CAD data and adjust the reworking of the fingers accordingly.

## Tolerance compensation unit TCU

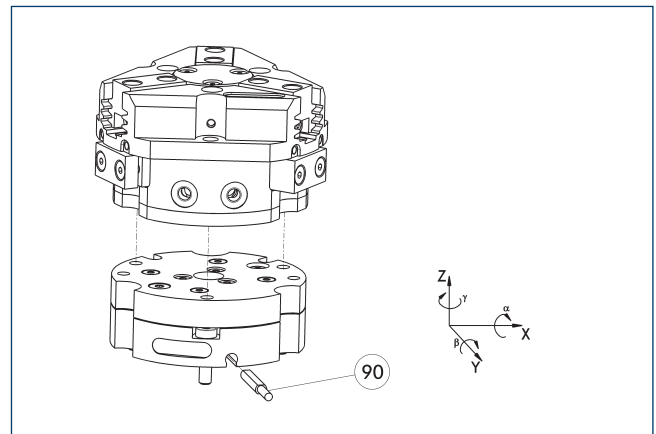

⑨⑩ Monitoring of locking

Grippers can be directly mounted without an adapter plate. Tolerance compensation unit and gripper have an identical screw connection diagram. Therefore the tolerance compensation units can be assembled later. Please consider the additional assembly height of the tolerance compensation unit. For details please refer to our catalog robot accessories.

Description	ID	Locking	Deflection	Often combined
Compensation unit				
TCU-Z-125-3-MV	0324820	yes	$\pm 1^\circ / \pm 1^\circ / \pm 1^\circ$	●
TCU-Z-125-3-0V	0324821	no	$\pm 1^\circ / \pm 1^\circ / \pm 1^\circ$	

## Compensation unit AGE-F

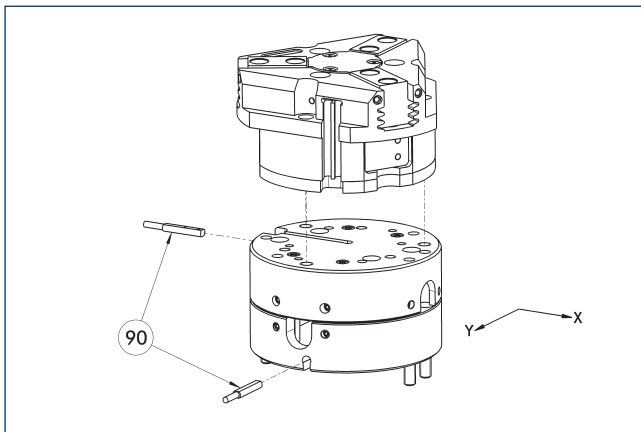

⑨⑩ Monitoring

Grippers can be directly mounted without an adapter plate. For details see our catalog Gripping or Robot Accessories.

Description	ID	Compensation XY	Reset force	Often combined
		[mm]	[N]	
Compensation unit				
AGE-F-XY-080-1	0324960	$\pm 5$	39	
AGE-F-XY-080-2	0324961	$\pm 5$	85	
AGE-F-XY-080-3	0324962	$\pm 5$	90	●



# PZN-plus 125

Universal gripper

## Inductive proximity switches

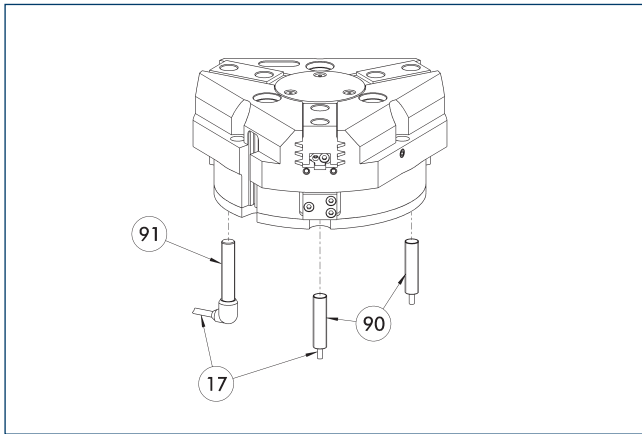

17 Cable outlet

91 Sensor IN..-SA

90 Sensor IN ...

Directly mounted end position monitoring.

Description	ID	Often combined
<b>Inductive proximity switches</b>		
IN 80-S-M12	0301578	
IN 80-S-M8	0301478	●
INK 80-S	0301550	
<b>Inductive proximity switch with lateral cable outlet</b>		
IN 80-S-M12-SA	0301587	
IN 80-S-M8-SA	0301483	●
INK 80-S-SA	0301566	
<b>Connection cables</b>		
KA BG08-L 3P-0300-PNP	0301622	●
KA BG08-L 3P-0500-PNP	0301623	
KA BG12-L 3P-0500-PNP	30016369	
KA BW08-L 3P-0300-PNP	0301594	
KA BW08-L 3P-0500-PNP	0301502	
KA BW12-L 3P-0300-PNP	0301503	
KA BW12-L 3P-0500-PNP	0301507	
<b>Clip for connector/socket</b>		
CLI-M12	0301464	
CLI-M8	0301463	
<b>Cable extension</b>		
KV BG12-SG12 3P-0030-PNP	0301999	
KV BG12-SG12 3P-0060-PNP	0301998	
KV BW08-SG08 3P-0030-PNP	0301495	
KV BW08-SG08 3P-0100-PNP	0301496	
KV BW08-SG08 3P-0200-PNP	0301497	●
KV BW12-SG12 3P-0030-PNP	0301595	
KV BW12-SG12 3P-0100-PNP	0301596	
KV BW12-SG12 3P-0200-PNP	0301597	
<b>Sensor distributor</b>		
V2-M12	0301776	●
V2-M8	0301775	●
V4-M8	0301746	
V8-M8	0301751	

① Two sensors are required per unit for monitoring two positions. On option, extension cables and sensor distributors are available. Additional product variants of the sensor, and further information and technical data can be found in the catalog chapter sensor system.

### Flexible position sensor

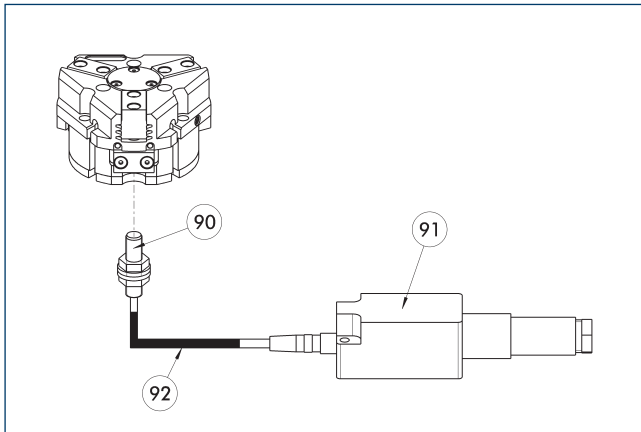

- ⑨⑩ FPS-S sensor
- ⑨① FPS-F5 evaluation electronic
- ⑨② Cable extension

Flexible position monitoring of up to five positions.

Description	ID	
<b>Attachment kit for FPS</b>		
AS-FPS-PGZN-plus 125-1/PZB 160	0301636	
AS-FPS-PGZN-plus 125-2	0301637	
<b>Sensor</b>		
FPS-S M8	0301704	
<b>Evaluation electronics</b>		
FPS-F5	0301805	
<b>Cable extension</b>		
KV BG08-SG08 3P-0050	0301598	
KV BG08-SG08 3P-0100	0301599	

- ① When using an FPS system, an FPS sensor (FPS-S) as well as an electronic processor (FPS-F5 / F5 T) are required for each gripper as well as a mounting kit (AS), if listed. Cable extensions (KV) are optionally available – see catalog chapter "Accessories."

### Electronic magnetic switch MMS

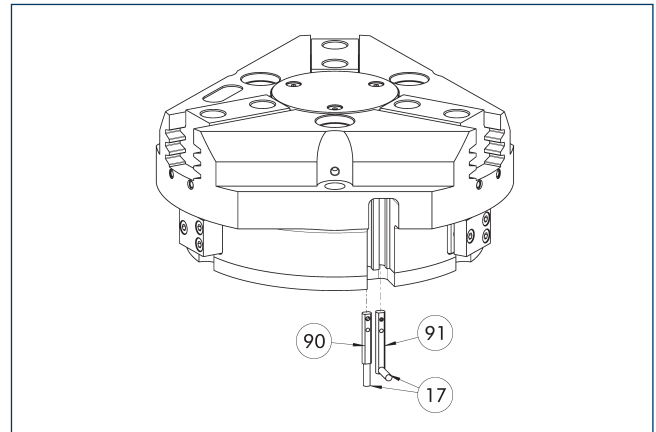

- ①⑦ Cable outlet
- ①⑨ Sensor MMS 22..
- ①⑩ Sensor MMS 22...-SA

End position monitoring for mounting in the C-slot.

Description	ID	Often combined
<b>Electronic magnetic switch</b>		
MMS 22-S-M8-PNP	0301032	●
MMSK 22-S-PNP	0301034	
<b>Electronic magnetic switches with lateral cable outlet</b>		
MMS 22-S-M8-PNP-SA	0301042	●
MMSK 22-S-PNP-SA	0301044	
<b>Reed Switches</b>		
RMS 22-S-M8	0377720	●
<b>Connection cables</b>		
KA BG08-L 3P-0300-PNP	0301622	●
KA BG08-L 3P-0500-PNP	0301623	
KA BW08-L 3P-0300-PNP	0301594	
KA BW08-L 3P-0500-PNP	0301502	
<b>Clip for connector/socket</b>		
CLI-M8	0301463	
<b>Cable extension</b>		
KV BW08-SG08 3P-0030-PNP	0301495	
KV BW08-SG08 3P-0100-PNP	0301496	
KV BW08-SG08 3P-0200-PNP	0301497	●
<b>Sensor distributor</b>		
V2-M8	0301775	●
V4-M8	0301746	
V8-M8	0301751	

- ① Two sensors are required per unit for monitoring two positions. On option, extension cables and sensor distributors are available. Additional product variants of the sensor, and further information and technical data can be found in the catalog chapter sensor system.

### Programmable magnetic switch MMS 22-PI1

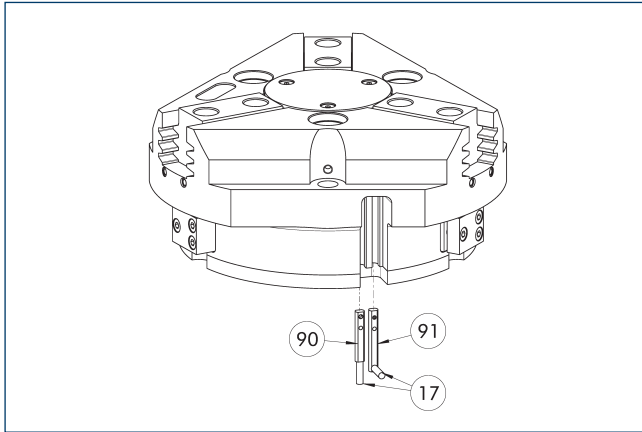

- ⑰ Cable outlet
- ⑨① Sensor MMS 22 ..-PI1-...-SA
- ⑨① Sensor MMS 22 PI1-...

Position monitoring with one programmable position per sensor and integrated electronic system in the sensor. Can be programmed using MT magnetic teaching tool (included in the scope of delivery, ID 0301030) or ST plug teaching tool (optional). End position monitoring for mounting in the C-slot. If the ST plug teaching tools are listed in the table provided, teaching is only possible with the ST teaching tools.

Description	ID	Often combined
<b>Programmable magnetic switch</b>		
MMS 22-PI1-S-M8-PNP	0301160	●
MMSK 22-PI1-S-PNP	0301162	
<b>Programmable magnetic switch with lateral cable outlet</b>		
MMS 22-PI1-S-M8-PNP-SA	0301166	●
MMSK 22-PI1-S-PNP-SA	0301168	
<b>Programmable magnetic switch with stainless steel housing</b>		
MMS 22-PI1-S-M8-PNP-HD	0301110	●
MMSK 22-PI1-S-PNP-HD	0301112	

- ① Two sensors are required per unit for monitoring two positions. On option, extension cables and sensor distributors are available. Additional product variants of the sensor, and further information and technical data can be found in the catalog chapter sensor system.

### Programmable magnetic switch MMS 22-PI2

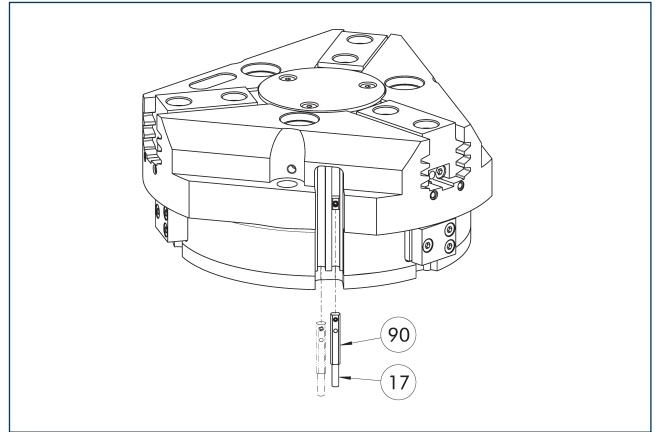

- ⑰ Cable outlet
- ⑨① MMS 22...-PI2-... sensor

Position monitoring with two programmable positions per sensor and electronics integrated in the sensor. Can be programmed using MT magnetic teaching tool (included in the scope of delivery, ID 0301030) or ST plug teaching tool (optional). End position monitoring for mounting in the C-slot. If the ST plug teaching tools are listed in the table provided, teaching is only possible with the ST teaching tools.

Description	ID	Often combined
<b>Programmable magnetic switch</b>		
MMS 22-PI2-S-M8-PNP	0301180	●
MMSK 22-PI2-S-PNP	0301182	
<b>Programmable magnetic switch with lateral cable outlet</b>		
MMS 22-PI2-S-M8-PNP-SA	0301186	●
MMSK 22-PI2-S-PNP-SA	0301188	
<b>Programmable magnetic switch with stainless steel housing</b>		
MMS 22-PI2-S-M8-PNP-HD	0301130	●
MMSK 22-PI2-S-PNP-HD	0301132	

- ① One sensor is required per unit for monitoring two positions. Extension cables and sensor distributors are optionally available. Additional product variants of the sensor, and further information and technical data can be found in the catalog chapter sensor systems.

## MMS-P programmable magnetic switch

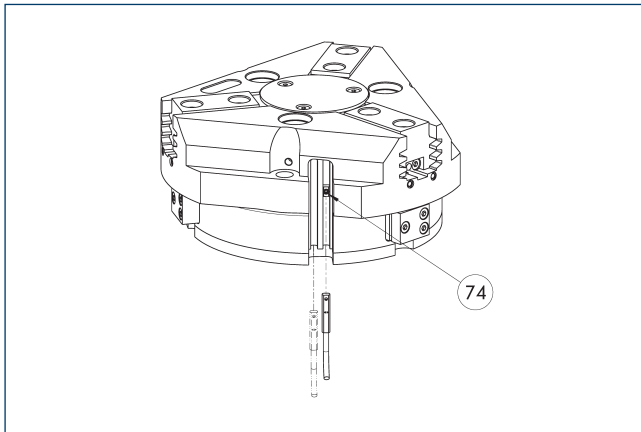

74 Limit stop for sensor

Position monitoring with two programmable positions per sensor. End position monitoring for mounting in the C-slot.

Description	ID	Often combined
Programmable magnetic switch		
MMSK-P 22-S-PNP	0301371	
MMS-P 22-S-M8-PNP	0301370	●
Connection cables		
KA GLN0804-LK-00500-A	0307767	●
KA GLN0804-LK-01000-A	0307768	
KA WLN0804-LK-00500-A	0307765	
KA WLN0804-LK-01000-A	0307766	
Clip for connector/socket		
CLI-M8	0301463	
Sensor distributor		
V2-M8-4P-2XM8-3P	0301380	

- ① One sensor is required per unit for monitoring two positions. Extension cables and sensor distributors are optionally available. Additional product variants of the sensor, and further information and technical data can be found in the catalog chapter sensor systems.

## Programmable magnetic switch MMS-IO-Link

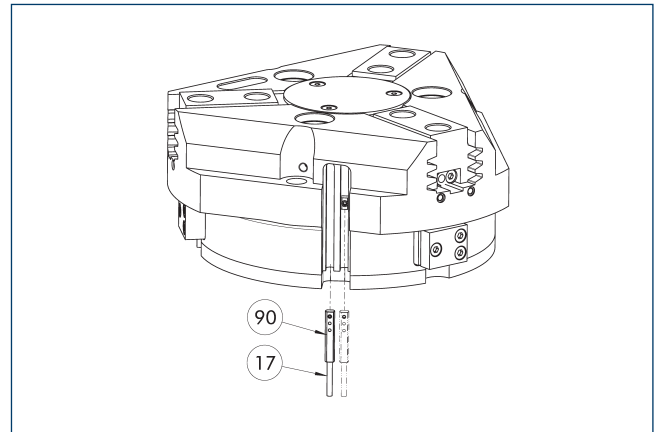

17 Cable outlet

90 Sensor MMS 22-IO-Link...

Sensor for multi-position monitoring through detection of the complete gripper stroke. The sensor is mounted directly in the C-slot of the gripper. The sensor is programmed for the gripper via the IO-Link interface, Magnet teaching tool MT (included in scope of delivery; ID 0301030) or the ST plug teaching tool (not included in scope of delivery; ID 0301026). An IO-Link master is required for operation.

Description	ID	
Programmable magnetic switch		
MMS 22-IO-Link-M08	0315830	
MMS 22-IO-Link-M12	0315835	

- ① One sensor is required for each gripper. No additional mounting kit is required – the gripper is equipped for use of the sensor by default. Further information and technical data can be found in the catalog chapter sensor systems.

# PZN-plus 125

Universal gripper

## APS-Z80 analog position sensor

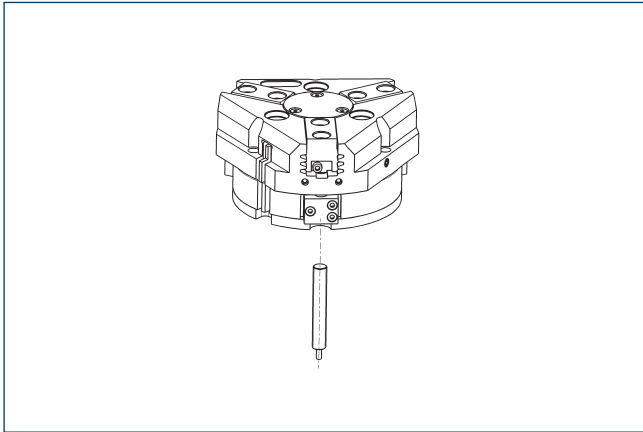

Non-contact measuring, analog multi-position monitoring for any number of positions.

Description	ID	Often combined
Mounting kit for APS-Z80		
AS-APS-Z80-PGZN-plus 125-1	0302111	
AS-APS-Z80-PGZN-plus 125-2	0302112	
Analog position sensor		
APS-Z80-K	0302072	
APS-Z80-M8	0302070	●

① When using an APS system, one mounting kit (AS-APS-Z80) and one APS-Z80 sensor is required per gripper. The resolution of the sensor can be lower in the peripheral areas of the gripper. You can find further information on the product in the operating manual.

## APS-M1 analog position sensor

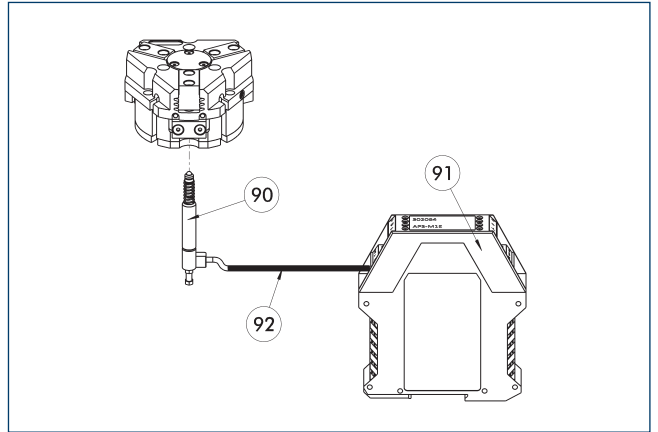

- ⑨⑩ APS-M1S sensor
- ⑨① APS-M1E electronic processor
- ⑨② APS-K extension cable

Analog multi position monitoring for any desired positions

Description	ID	
Mounting kit for APS-M1		
AS-APS-M1-PGZN-plus 125-1	0302081	
AS-APS-M1-PGZN-plus 125-2	0302082	
Analog position sensor		
APS-M1S	0302062	
Connection cables		
APS-K0200	0302066	
APS-K0700	0302068	
Evaluation electronics		
APS-M1E	0302064	

① When using an APS system, for each gripper an attachment kit (AS-APS-M1), an APS-M1S sensor (incl. 3 m cable) as well as an electronics (APS-M1e) are required. An extension cable (APS-K) can be connected between the sensor and the electronics as an option. The max. cable length between the sensor and the electronics is 10 m, between the electronics and their control unit (PLC) it is max. 1 m.

## Cylindrical reed switches

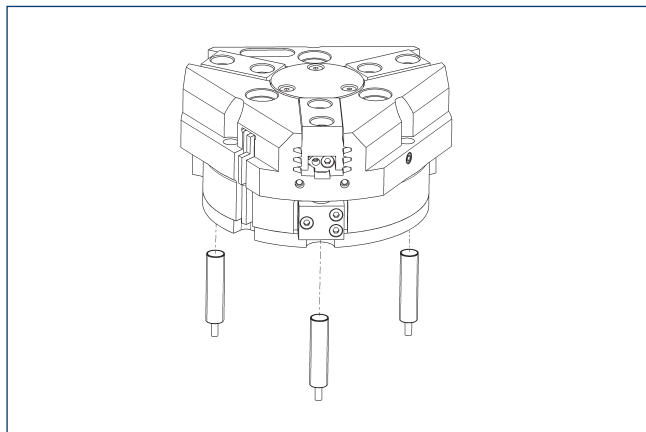

End position monitoring can be mounted with an attachment kit.

Description	ID	
Attachment kit for proximity switch		
AS-RMS 80 PGN/PZN-plus 100/125	0377726	
Reed Switches		
RMS 80-S-M8	0377721	

- ① Two sensors (closer/S) are required for each unit and extension cables are available as an option. This attachment kit needs to be ordered optionally as an accessory. Two mounting kits are required for each gripper. For sensor cables, note the minimum permissible bending radii. These are generally 35 mm.