

# PZN-plus 64

Universal gripper

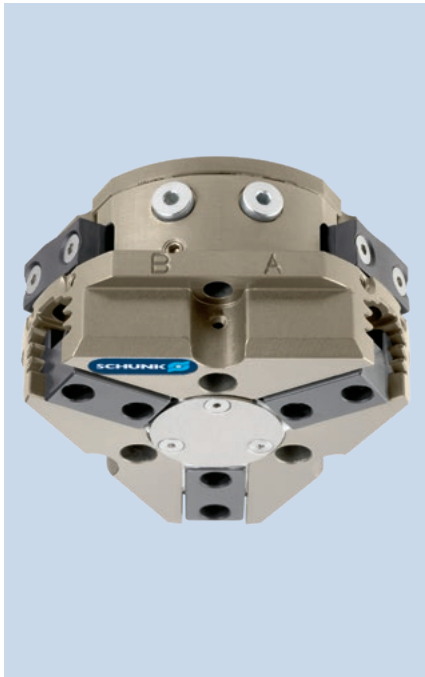

## Gripping force O.D. gripping

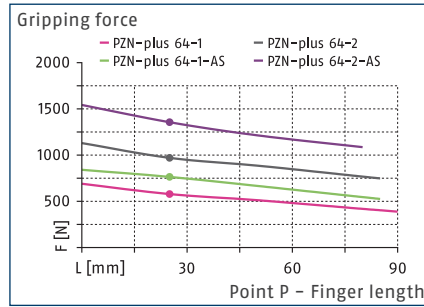

## Gripping force I.D. gripping

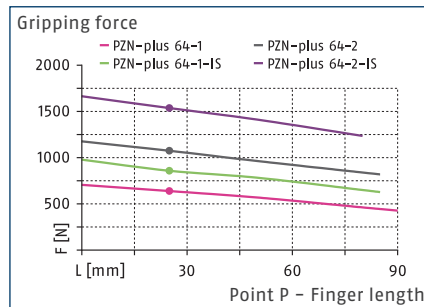

## Dimensions and maximum loads

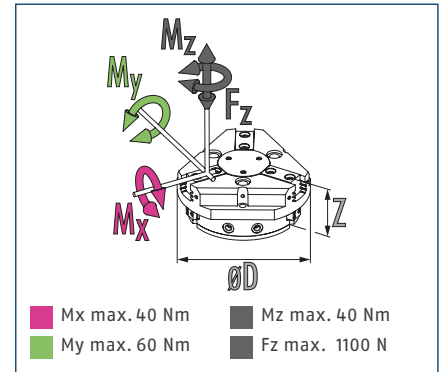

① The indicated moments and forces are static values, apply for each base jaw and may appear simultaneously. Loads may additionally occur to the moment produced by the gripping force itself.

## Technical data

Description		PZN-plus 64-1	PZN-plus 64-2	PZN-plus 64-1-AS	PZN-plus 64-2-AS	PZN-plus 64-1-IS	PZN-plus 64-2-IS
ID		0303310	0303410	0303510	0303610	0303540	0303640
Stroke per jaw	[mm]	6	3	6	3	6	3
Closing/opening force	[N]	580/640	970/1075	765/-	1285/-	-/860	-/1535
Min. spring force	[N]			185	315	220	460
Weight	[kg]	0.43	0.43	0.54	0.54	0.54	0.54
Recommended workpiece weight	[kg]	2.9	4.85	2.9	4.85	2.9	4.85
Cylinder volume per double stroke	[cm <sup>3</sup> ]	25	25	48	48	48	48
Min./nom./max. operating pressure	[bar]	2/6/8	2/6/8	4/6/6.5	4/6/6.5	4/6/6.5	4/6/6.5
Min./max. air purge pressure	[bar]	0.5/1	0.5/1	0.5/1	0.5/1	0.5/1	0.5/1
Closing/opening time	[s]	0.03/0.03	0.03/0.03	0.02/0.04	0.02/0.04	0.04/0.02	0.04/0.02
Closing/opening time with spring	[s]			0.08	0.08	0.08	0.08
Max. permissible finger length	[mm]	90	85	85	80	85	80
Max. permissible weight per finger	[kg]	0.35	0.35	0.35	0.35	0.35	0.35
IP protection class		40	40	40	40	40	40
Min./max. ambient temperature	[°C]	5/90	5/90	5/90	5/90	5/90	5/90
Repeat accuracy	[mm]	0.01	0.01	0.01	0.01	0.01	0.01
Dimensions Ø D x Z	[mm]	76 x 43.3	76 x 43.3	76 x 56.8	76 x 56.8	76 x 56.8	76 x 56.8
<b>Options and their characteristics</b>							
Dustproof version		37303310	37303410	37303510	37303610	37303540	37303640
IP protection class		64	64	64	64	64	64
Weight	[kg]	0.6	0.6	0.71	0.71	0.71	0.71
Corrosion-protected version		38303310	38303410	38303510	38303610	38303540	38303640
High-temperature version		39303310	39303410	39303510	39303610	39303540	39303640
Min./max. ambient temperature	[°C]	5/130	5/130	5/130	5/130	5/130	5/130
Power booster version		0372201	0372211	0372221		0372241	
Closing/opening force	[N]	933/1083	1585/1833	1153/-		-/1250	
Weight	[kg]	0.7	0.7	0.8		0.8	
Maximum pressure	[bar]	6	6	6		6	
Max. permissible finger length	[mm]	80	64	64		64	
Precision version		0303340	0303440	0303490	0303590		

① It may take a few 100 gripping cycles until the full gripping force (as indicated in the data table) will be available.

## Main view

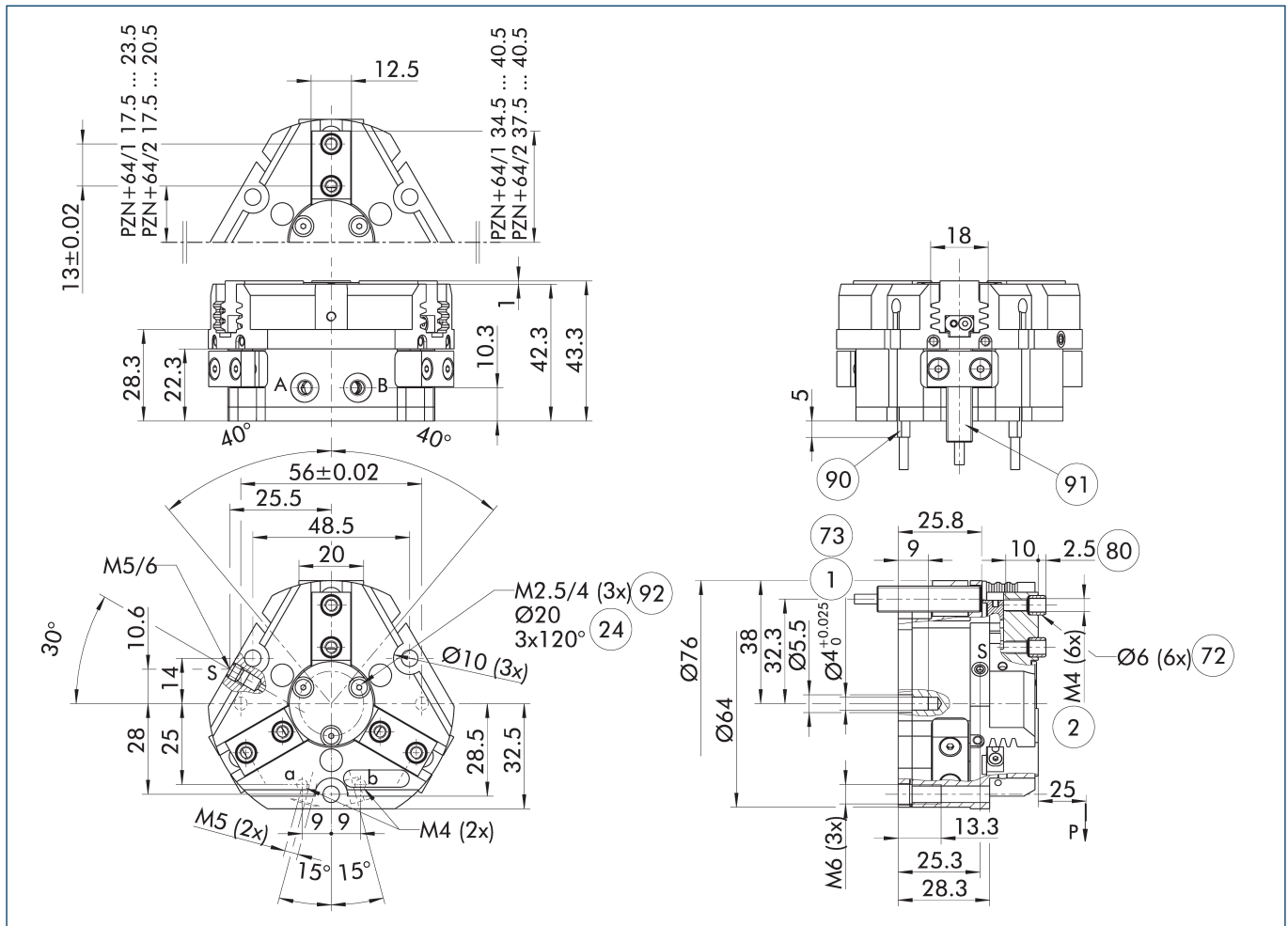

The drawing shows the gripper in the basic version with closed jaws, without dimensional consideration of the options described below.

① As an alternative/in addition to spring-assisted mechanical gripping force maintenance, the SDV-P pressure maintenance valve can be used for I.D. and O.D. gripping (see "Accessories" section of catalog).

- |  |  |
|--|--|
| A, a Main / direct connection, gripper opening | ⑦② Fit for centering sleeves                                 |
| B, b Main / direct connection, gripper closing | ⑦③ Fit for centering pins                                    |
| S Air purge connection                         | ⑧① Depth of the centering sleeve hole in the counter part    |
| ① Gripper connection                           | ⑨① Sensor MMS 22..   |
| ② Finger connection                            | ⑨① Sensor IN ...   |
| ②④ Bolt circle                                 | ⑨② Thread below the cover for fastening external attachments |

# PZN-plus 64

Universal gripper

## Hose-free direct connection M4

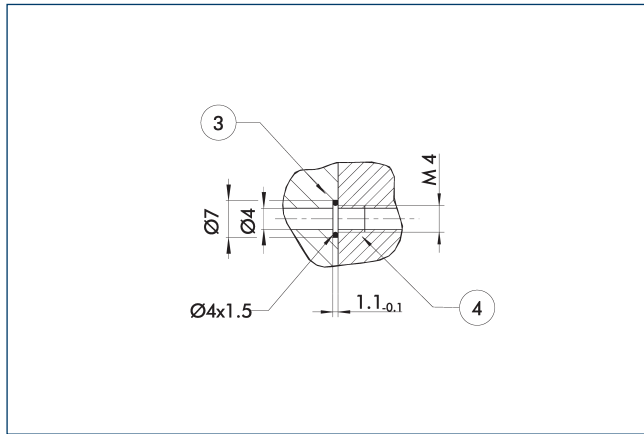

- ③ Adapter
- ④ Grippers

The direct connection is used for supplying compressed air without hoses. Instead, the pressure medium is fed through bore-holes in the mounting plate.

## Gripping force maintenance version AS/IS

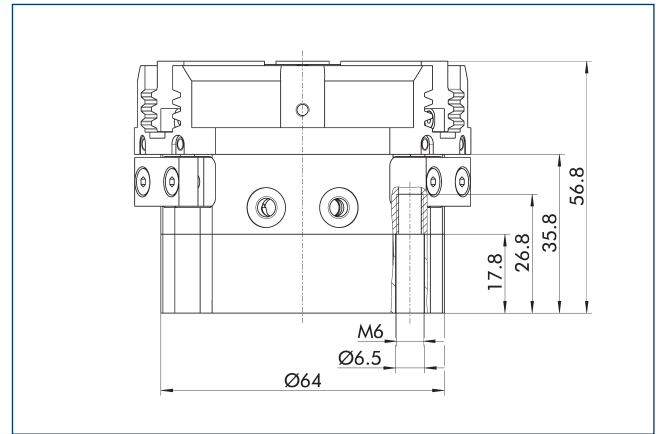

The mechanical gripping force maintenance device ensures that a minimum clamping force will be applied even if there is a drop in pressure. In the AS/IS variant this acts as a closing force, in the IS variant as an opening force. Besides this, gripping force maintenance can be used to increase gripping force or for single actuated gripping.

## Dustproof version

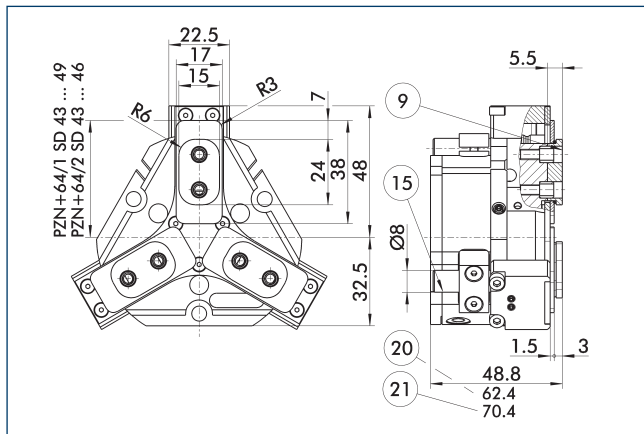

- ⑨ For mounting screw connection
- ⑩ For version AS/IS diagram, see basic version
- ⑪ Sealing bolt
- ⑫ Applies for KVZ version

The "dustproof" option increases the degree of protection against penetrating substances. The assembly diagram shifts by the height of the intermediate jaw. The finger length is still measured from the upper edge of the gripper housing.

## Power booster version

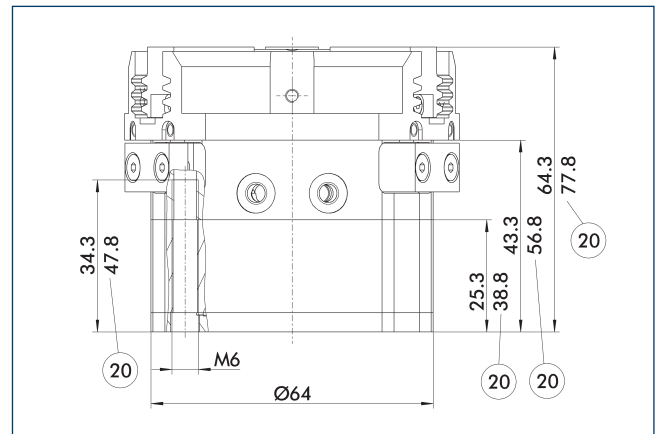

- ⑫ For version AS/IS

The KVZ cylinder increases the gripping forces during opening and closing. A second, in series-connected piston also increases the force on the wedge hook. Please consider that grippers which are equipped with a gripping force maintenance device are higher.

### Precision version

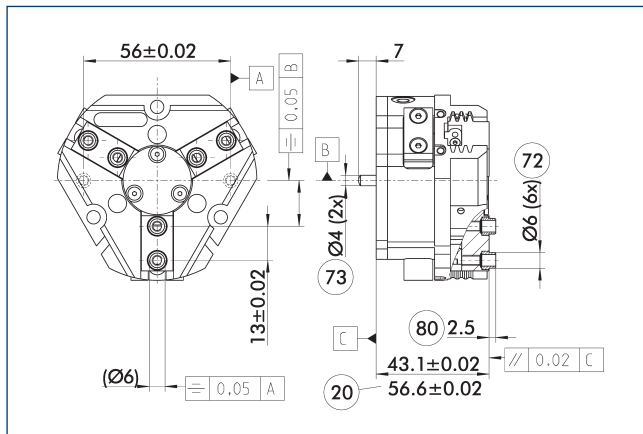

- ②0 For version AS/IS
- ⑦2 Fit for centering sleeves
- ⑦3 Fit for centering pins
- ⑧0 Depth of the centering sleeve hole in the counter part

The indicated tolerances just refer to the variants of precision versions shown in the chart of technical specifications. All other variants of precision versions are available on request.

### Spring-loaded pressure piece

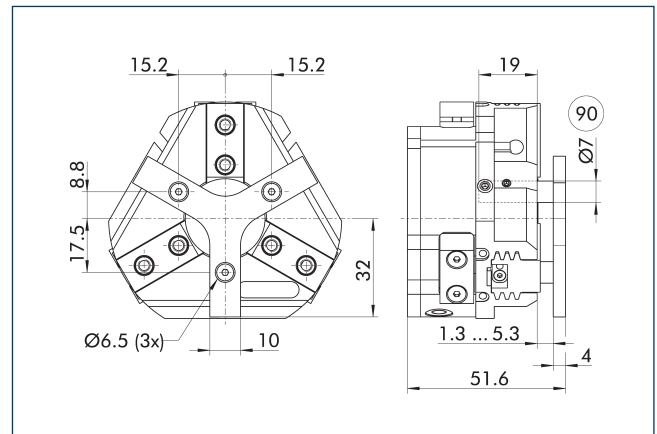

- ⑨0 Guide pin

For spring-supported positioning of the workpiece against a stop after the gripper has opened. Especially developed for loading machines.

Description	ID	Stroke [mm]	Min. force [N]
Spring-loaded pressure piece			
A-PZN-plus/DPZ-plus 64	0303720	4	11

- ① The pressure piece cannot be combined with the dustproof option. Please contact us if you require a customized pressure piece.

### SDV-P pressure maintenance valve

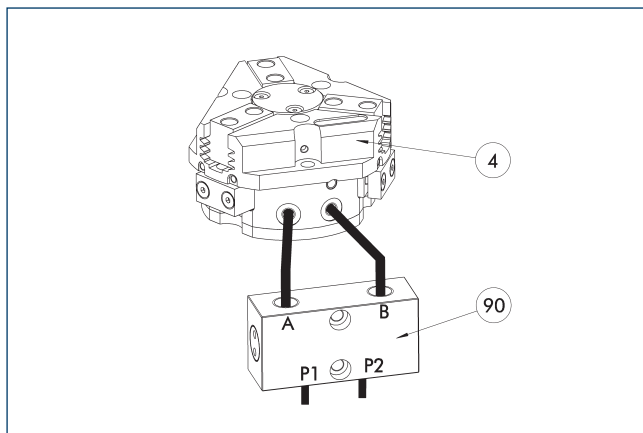

- ④ Grippers
- ⑨0 SDV-P pressure maintenance valve

The SDV-P pressure maintenance valve ensures in emergency STOP situations that the pressure in the piston chamber of pneumatic gripper, swivel, linear, and quick-change modules is temporarily maintained.

Description	ID	Recommended hose diameter [mm]
Pressure maintenance valve		
SDV-P 04	0403130	6
SDV-P 07	0403131	8
Pressure maintenance valve with air bleed screw		
SDV-P 04-E	0300120	6
SDV-P 07-E	0300121	8
SDV-P 10-E	0300109	10

- ① In order to achieve the specified closing and opening time for each gripper variant, the recommended hose diameter must be used. The direct allocation of the respective variant of the gripper for the respective SDV-P can be found at schunk.com.

### Pneumatic positioning device PPD

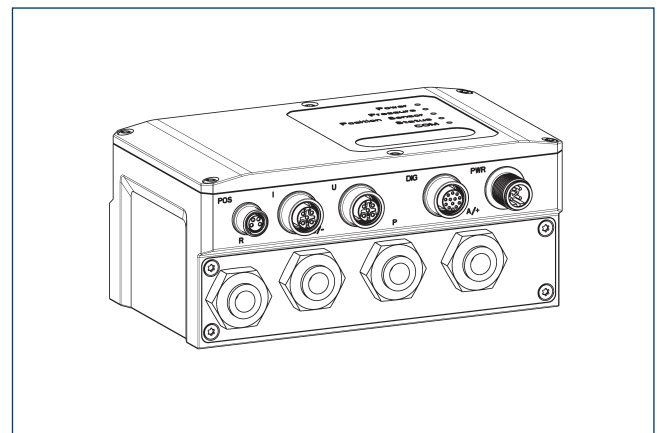

The PPD allows flexibility in all applications with pneumatic grippers through free positioning, gripping force and speed adjustment.

Description	ID	
Pneumatic positioning device		
PPD 20-IOL	1540700	
Adapter		
A GGN0804-1204-A	1540691	
IO-Link connection cable		
KA GGN1205-1212-IOL-00100-A	1540697	
Voltage supply connection cable - cable track compatible		
KA GLN12B05-LK-01000-A	1540660	
Cable extension		
KV GGN0804-I0-00150-A	1540662	
KV GGN0804-I0-00300-A	1540663	
Assembly set		
Assembly set PPD	1540705	

- ① In addition to the PPD, a position sensor (SCHUNK IO-Link sensor or analog sensor (4...20 mA)) is required.

# PZN-plus 64

Universal gripper

## Protective cover HUE PZN-plus 64

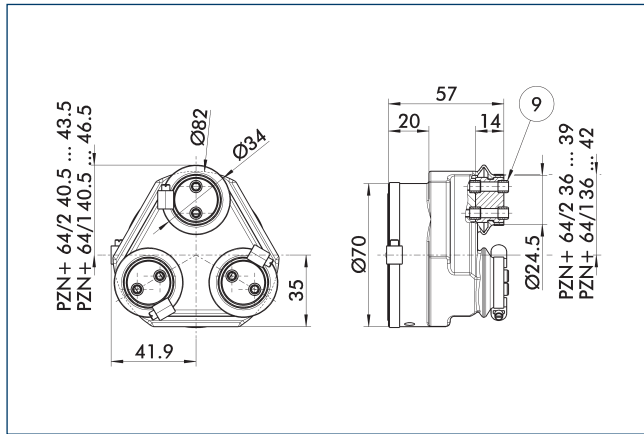

⑨ For mounting screw connection diagram, see basic version

The HUE protective cover fully protects the gripper against external influences. The cover is suitable for applications of up to IP65 if an additional sealing of the cover bottom is provided. For detailed information, please see the HUE series. The connection diagram shifts by the height of the intermediate jaw.

Description	ID	IP protection class
Protection cover		
HUE PZN-plus 64	0303480	65

⑩ An inductive monitoring of the gripper in connection with the protective cover HUE is not possible. SCHUNK recommends the use of magnetic sensors that are approved for the respective gripper version.

## BSWS jaw quick-change jaw systems

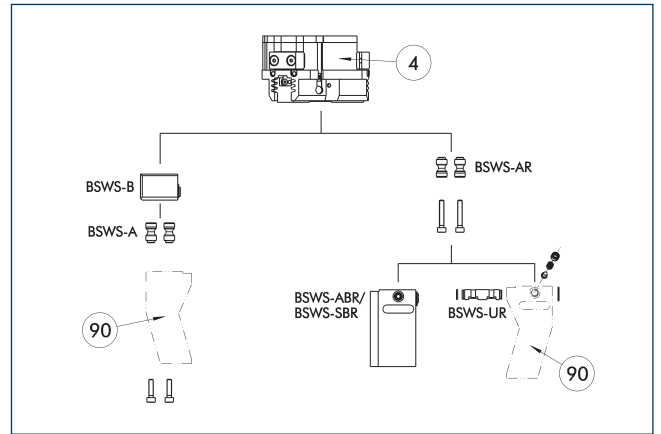

④ Grippers

⑨⑩ Customized gripper fingers

There are various jaw quick-change systems available for the gripper. For detailed information, please refer to the corresponding product.

Description	ID	Scope of delivery
Jaw quick-change system adapter pin		
BSWS-A 64	0303022	2
BSWS-AR 64	0300092	2
Quick-change jaw system base		
BSWS-B 64	0303023	1
Jaw quick-change system finger blank		
BSWS-ABR-PGZN-plus 64	0300072	1
BSWS-SBR-PGZN-plus 64	0300082	1
Jaw quick-change system locking mechanism		
BSWS-UR 64	0302991	1

⑩ If the operating pressure is higher than 6 bar, suitability for use beyond the application limits must be checked. Only systems that are listed in the table, can be used.

### Fields of application

Series	Size	Variant	Suitability
PZN-plus	64	-1 (6 bar)	■■■■■
PZN-plus	64	-1-AS/1-IS (6 bar)	■■■■■
PZN-plus	64	-2 (6 bar)	■■■■■
PZN-plus	64	-2-AS/2-IS (6 bar)	■■■□□
PZN-plus	64	-...-KVZ (6 bar)	■■■□□
Legend			
■■■■■	Can be combined without restrictions		
■■■□□	Use with restrictions (see loading limits)		
□□□□□	cannot be combined		

The load limits for describing the application limits can be found in the catalog chapter of the corresponding accessories.





## Finger blanks ABR/SBR-PGZN-plus 64

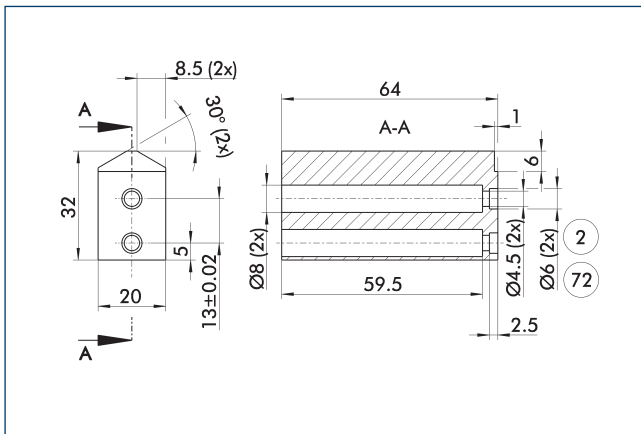

- ② Finger connection
- ⑦② Fit for centering sleeves

The drawing shows the finger blank which can be reworked by the customer.

Description	ID	Material	Scope of delivery
Finger blank			
ABR-PGZN-plus 64	0300010	Aluminum (3.4365)	1
SBR-PGZN-plus 64	0300020	Steel (1.7131)	1

- ① In the PGL-plus-P gripper series, the use of finger blanks results in a limitation of the closing stroke. Please check this in detail in advance using the CAD data and adjust the reworking of the fingers accordingly.

## Compensation unit AGE-F

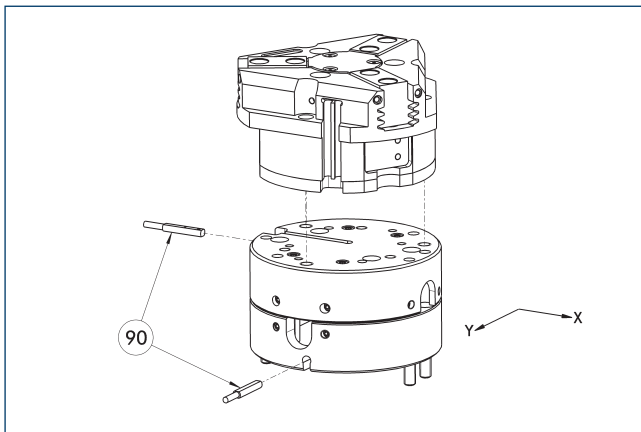

- ⑨⑩ Monitoring

Grippers can be directly mounted without an adapter plate. For details see our catalog Gripping or Robot Accessories.

Description	ID	Compensation XY	Reset force	Often combined
		[mm]	[N]	
Compensation unit				
AGE-F-XY-063-1	0324940	± 4	12	
AGE-F-XY-063-2	0324941	± 4	16	
AGE-F-XY-063-3	0324942	± 4	20	●

## Tolerance compensation unit TCU

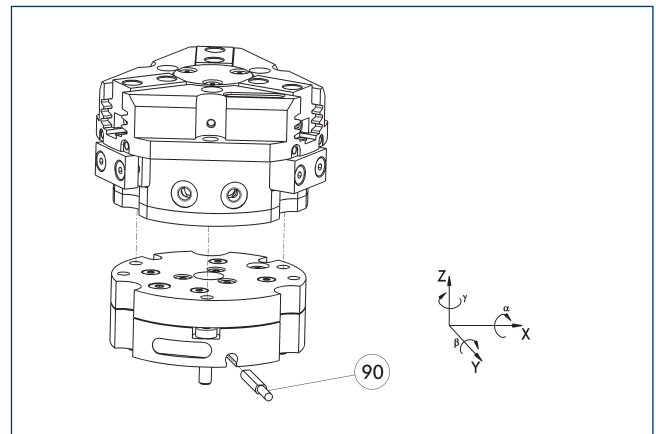

- ⑨⑩ Monitoring of locking

Grippers can be directly mounted without an adapter plate. Tolerance compensation unit and gripper have an identical screw connection diagram. Therefore the tolerance compensation units can be assembled later. Please consider the additional assembly height of the tolerance compensation unit. For details please refer to our catalog robot accessories.

Description	ID	Locking	Deflection	Often combined
Compensation unit				
TCU-Z-064-3-MV	0324766	yes	±1°/±1°/±1°	●
TCU-Z-064-3-0V	0324767	no	±1°/±1°/±1°	

## Modular Assembly Automation

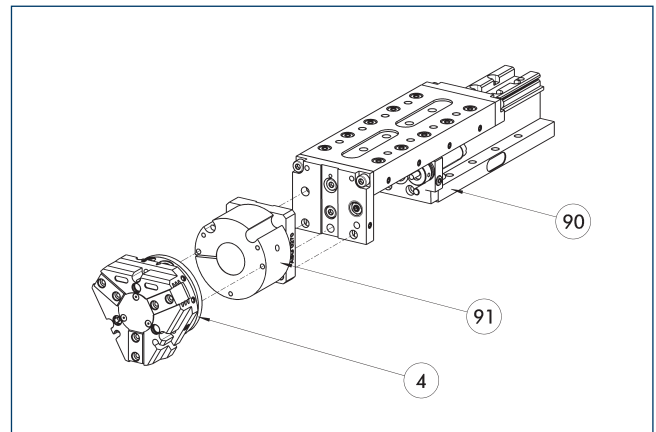

- ④ Grippers
- ⑨⑩ Linear module CLM/KLM/LM/ELP/ELM/ELS/HLM
- ⑨① ASG adapter plate

Grippers and linear modules can be combined with standard adapter plates from the modular assembly system. For more information see our main catalog "Modular Assembly Automation".



# PZN-plus 64

Universal gripper

## Inductive proximity switches

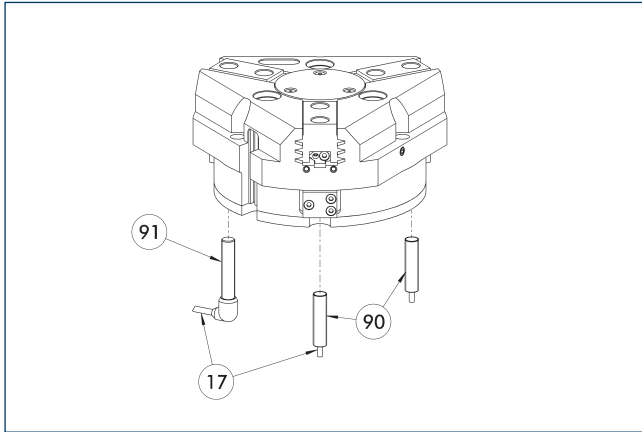

- 17 Cable outlet
- 90 Sensor IN ...
- 91 Sensor IN..-SA

Directly mounted end position monitoring.

Description	ID	Often combined
<b>Inductive proximity switches</b>		
IN 80-S-M12	0301578	
IN 80-S-M8	0301478	●
INK 80-S	0301550	
<b>Inductive proximity switch with lateral cable outlet</b>		
IN 80-S-M12-SA	0301587	
IN 80-S-M8-SA	0301483	●
INK 80-S-SA	0301566	
<b>Connection cables</b>		
KA BG08-L 3P-0300-PNP	0301622	●
KA BG08-L 3P-0500-PNP	0301623	
KA BG12-L 3P-0500-PNP	30016369	
KA BW08-L 3P-0300-PNP	0301594	
KA BW08-L 3P-0500-PNP	0301502	
KA BW12-L 3P-0300-PNP	0301503	
KA BW12-L 3P-0500-PNP	0301507	
<b>Clip for connector/socket</b>		
CLI-M12	0301464	
CLI-M8	0301463	
<b>Cable extension</b>		
KV BG12-SG12 3P-0030-PNP	0301999	
KV BG12-SG12 3P-0060-PNP	0301998	
KV BW08-SG08 3P-0030-PNP	0301495	
KV BW08-SG08 3P-0100-PNP	0301496	
KV BW08-SG08 3P-0200-PNP	0301497	●
KV BW12-SG12 3P-0030-PNP	0301595	
KV BW12-SG12 3P-0100-PNP	0301596	
KV BW12-SG12 3P-0200-PNP	0301597	
<b>Sensor distributor</b>		
V2-M12	0301776	●
V2-M8	0301775	●
V4-M8	0301746	
V8-M8	0301751	

- ① Two sensors are required per unit for monitoring two positions. On option, extension cables and sensor distributors are available. Additional product variants of the sensor, and further information and technical data can be found in the catalog chapter sensor system.

## Flexible position sensor

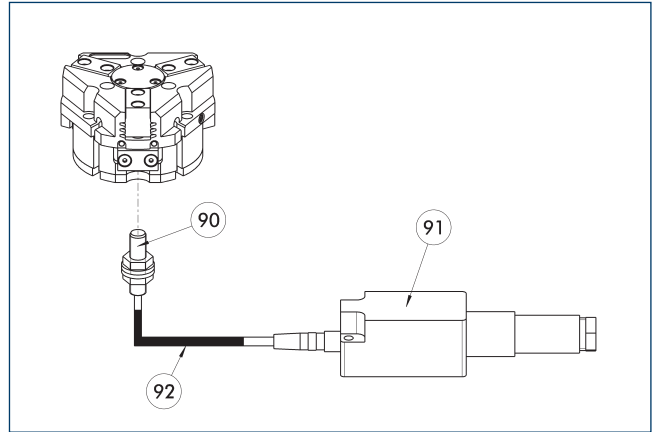

- 90 FPS-S sensor
- 91 FPS-F5 evaluation electronic
- 92 Cable extension

Flexible position monitoring of up to five positions.

Description	ID	
<b>Attachment kit for FPS</b>		
AS-FPS-PGZN-plus 64-1/80-2	0301630	
<b>Sensor</b>		
FPS-S M8	0301704	
<b>Evaluation electronics</b>		
FPS-F5	0301805	
<b>Cable extension</b>		
KV BG08-SG08 3P-0050	0301598	
KV BG08-SG08 3P-0100	0301599	

- ① When using an FPS system, an FPS sensor (FPS-S) as well as an electronic processor (FPS-F5 / F5 T) are required for each gripper as well as a mounting kit (AS), if listed. Cable extensions (KV) are optionally available – see catalog chapter “Accessories.”

## Electronic magnetic switch MMS

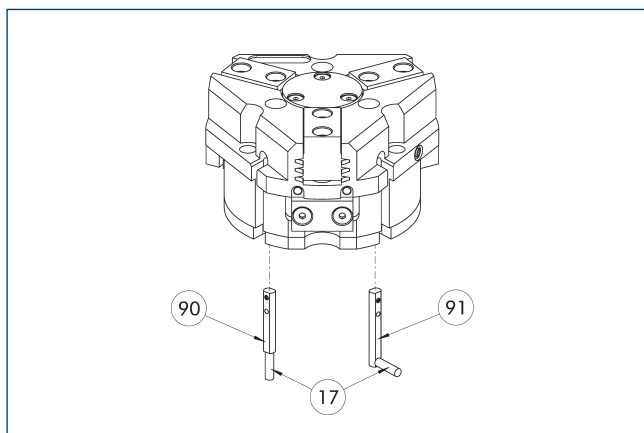

- ①⑦ Cable outlet
- ①⑨ Sensor MMS 22...-SA
- ①⑩ Sensor MMS 22..

End position monitoring for mounting in the C-slot.

Description	ID	Often combined
<b>Electronic magnetic switch</b>		
MMS 22-S-M8-PNP	0301032	●
MMSK 22-S-PNP	0301034	
<b>Electronic magnetic switches with lateral cable outlet</b>		
MMS 22-S-M8-PNP-SA	0301042	●
MMSK 22-S-PNP-SA	0301044	
<b>Connection cables</b>		
KA BG08-L 3P-0300-PNP	0301622	●
KA BG08-L 3P-0500-PNP	0301623	
KA BW08-L 3P-0300-PNP	0301594	
KA BW08-L 3P-0500-PNP	0301502	
<b>Clip for connector/socket</b>		
CLI-M8	0301463	
<b>Cable extension</b>		
KV BW08-SG08 3P-0030-PNP	0301495	
KV BW08-SG08 3P-0100-PNP	0301496	
KV BW08-SG08 3P-0200-PNP	0301497	●
<b>Sensor distributor</b>		
V2-M8	0301775	●
V4-M8	0301746	
V8-M8	0301751	

- ① Two sensors are required per unit for monitoring two positions. On option, extension cables and sensor distributors are available. Additional product variants of the sensor, and further information and technical data can be found in the catalog chapter sensor system.

## Programmable magnetic switch MMS 22-PI1

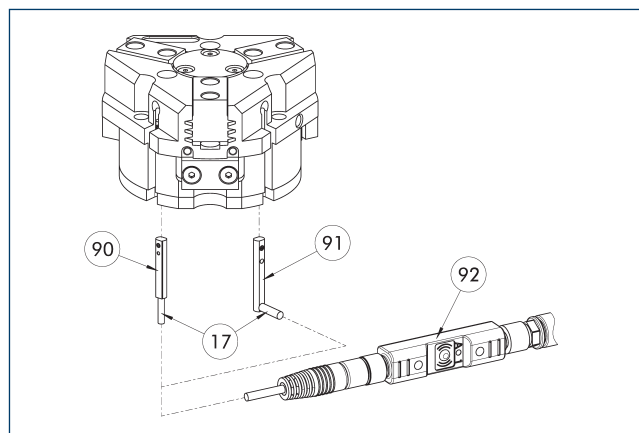

- ①⑦ Cable outlet
- ①⑨ Sensor MMS 22 ..-PI1...-SA
- ①⑩ Sensor MMS 22 PI1-...
- ①⑫ Connector teaching tool ST

Position monitoring with one programmable position per sensor and integrated electronic system in the sensor. Can be programmed using MT magnetic teaching tool (included in the scope of delivery, ID 0301030) or ST plug teaching tool (optional). End position monitoring for mounting in the C-slot. If the ST plug teaching tools are listed in the table provided, teaching is only possible with the ST teaching tools.

Description	ID	Often combined
<b>Programmable magnetic switch</b>		
MMS 22-PI1-S-M8-PNP	0301160	●
MMSK 22-PI1-S-PNP	0301162	
<b>Programmable magnetic switch with lateral cable outlet</b>		
MMS 22-PI1-S-M8-PNP-SA	0301166	●
MMSK 22-PI1-S-PNP-SA	0301168	
<b>Programmable magnetic switch with stainless steel housing</b>		
MMS 22-PI1-S-M8-PNP-HD	0301110	●
MMSK 22-PI1-S-PNP-HD	0301112	
<b>Plug teaching tool</b>		
ST-MMS 22-PI1-PNP	0301025	

- ① Two sensors are required per unit for monitoring two positions. On option, extension cables and sensor distributors are available. Additional product variants of the sensor, and further information and technical data can be found in the catalog chapter sensor system.

### Programmable magnetic switch MMS 22-PI2

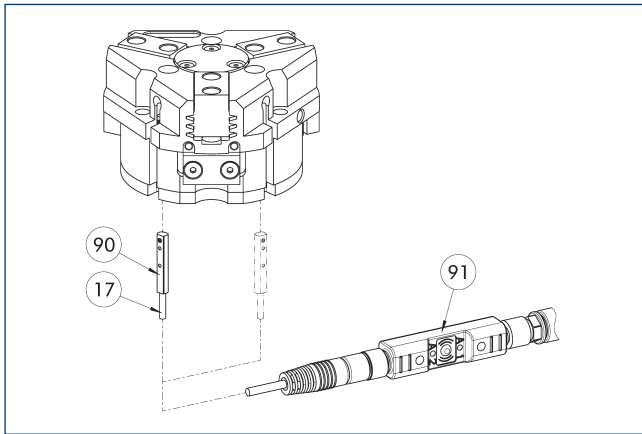

- ①⑦ Cable outlet
- ⑨① MMS 22...-PI2-... sensor
- ⑨① Connector teaching tool ST

Position monitoring with two programmable positions per sensor and electronics integrated in the sensor. Can be programmed using MT magnetic teaching tool (included in the scope of delivery, ID 0301030) or ST plug teaching tool (optional). End position monitoring for mounting in the C-slot. If the ST plug teaching tools are listed in the table provided, teaching is only possible with the ST teaching tools.

Description	ID	Often combined
<b>Programmable magnetic switch</b>		
MMS 22-PI2-S-M8-PNP	0301180	●
MMSK 22-PI2-S-PNP	0301182	
<b>Programmable magnetic switch with lateral cable outlet</b>		
MMS 22-PI2-S-M8-PNP-SA	0301186	●
MMSK 22-PI2-S-PNP-SA	0301188	
<b>Programmable magnetic switch with stainless steel housing</b>		
MMS 22-PI2-S-M8-PNP-HD	0301130	●
MMSK 22-PI2-S-PNP-HD	0301132	
<b>Plug teaching tool</b>		
ST-MMS 22-PI2-PNP	0301026	

- ① One sensor is required per unit for monitoring two positions. Extension cables and sensor distributors are optionally available. Additional product variants of the sensor, and further information and technical data can be found in the catalog chapter sensor systems.

### MMS-P programmable magnetic switch

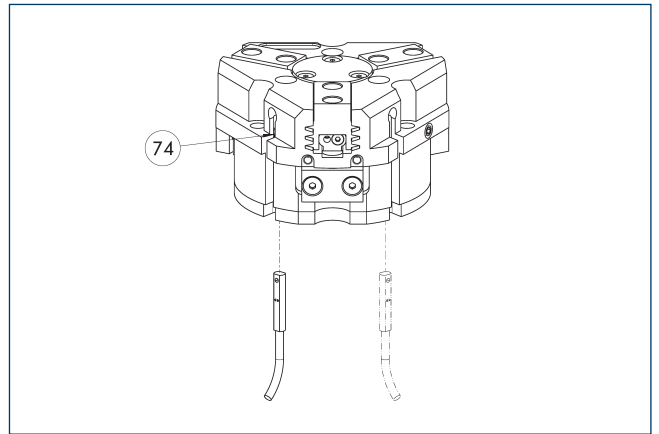

- ⑦④ Limit stop for sensor

Position monitoring with two programmable positions per sensor. End position monitoring for mounting in the C-slot.

Description	ID	Often combined
<b>Programmable magnetic switch</b>		
MMSK-P 22-S-PNP	0301371	
MMS-P 22-S-M8-PNP	0301370	●
<b>Connection cables</b>		
KA GLN0804-LK-00500-A	0307767	●
KA GLN0804-LK-01000-A	0307768	
KA WLN0804-LK-00500-A	0307765	
KA WLN0804-LK-01000-A	0307766	
<b>Clip for connector/socket</b>		
CLI-M8	0301463	
<b>Sensor distributor</b>		
V2-M8-4P-2XM8-3P	0301380	

- ① One sensor is required per unit for monitoring two positions. Extension cables and sensor distributors are optionally available. Additional product variants of the sensor, and further information and technical data can be found in the catalog chapter sensor systems.

## Programmable magnetic switch MMS-IO-Link

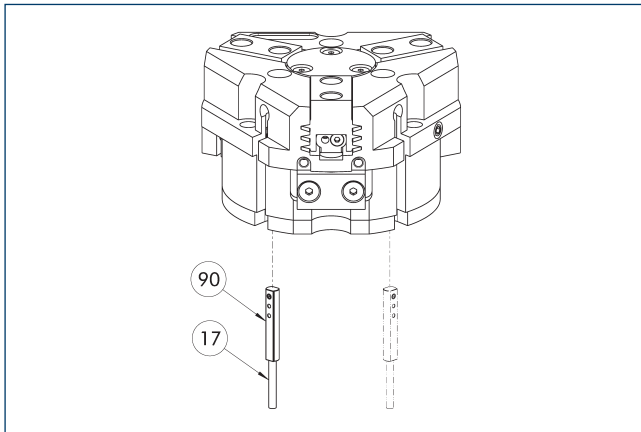

⑰ Cable outlet

⑨⑩ Sensor MMS 22-IO-L...

Sensor for multi-position monitoring through detection of the complete gripper stroke. The sensor is mounted directly in the C-slot of the gripper. The sensor is programmed for the gripper via the IO-Link interface or the ST plug teaching tool (not included in scope of delivery; ID 0301026). It is not possible to program the sensor using the Magnet teaching tool MT. An IO-Link master is required for operation.

Description	ID	
Programmable magnetic switch		
MMS 22-IO-L-M08	0315830	
MMS 22-IO-L-M12	0315835	

- ① One sensor is required for each gripper. No additional mounting kit is required – the gripper is equipped for use of the sensor by default. Further information and technical data can be found in the catalog chapter sensor systems.

## APS-Z80 analog position sensor

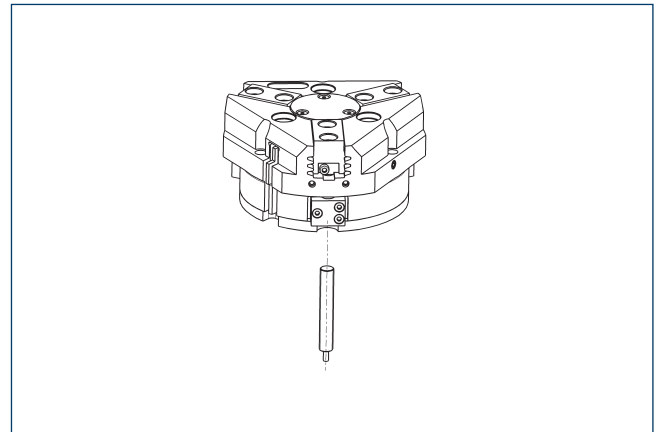

Non-contact measuring, analog multi-position monitoring for any number of positions.

Description	ID	Often combined
Mounting kit for APS-Z80		
AS-APS-Z80-PGZN-plus 64-1	0302105	
AS-APS-Z80-PGZN-plus 64-2	0302106	
Analog position sensor		
APS-Z80-K	0302072	
APS-Z80-M8	0302070	●

- ① When using an APS system, one mounting kit (AS-APS-Z80) and one APS-Z80 sensor is required per gripper. The resolution of the sensor can be lower in the peripheral areas of the gripper. You can find further information on the product in the operating manual.

### APS-M1 analog position sensor

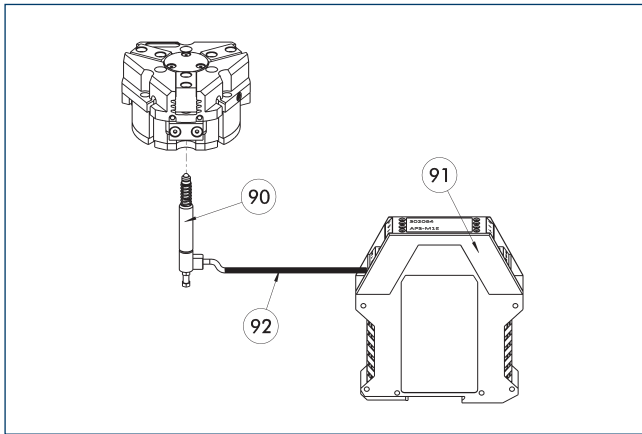

- ⑨⑩ APS-M1S sensor
- ⑨① APS-M1E electronic processor
- ⑨② APS-K extension cable

Analog multi position monitoring for any desired positions

Description	ID	
<b>Mounting kit for APS-M1</b>		
AS-APS-M1-PGZN-plus 64-1	0302075	
AS-APS-M1-PGZN-plus 64-2	0302076	
<b>Analog position sensor</b>		
APS-M1S	0302062	
<b>Connection cables</b>		
APS-K0200	0302066	
APS-K0700	0302068	
<b>Evaluation electronics</b>		
APS-M1E	0302064	

- ① When using an APS system, for each gripper an attachment kit (AS-APS-M1), an APS-M1S sensor (incl. 3 m cable) as well as an electronics (APS-M1e) are required. An extension cable (APS-K) can be connected between the sensor and the electronics as an option. The max. cable length between the sensor and the electronics is 10 m, between the electronics and their control unit (PLC) it is max. 1 m.

### Cylindrical reed switches

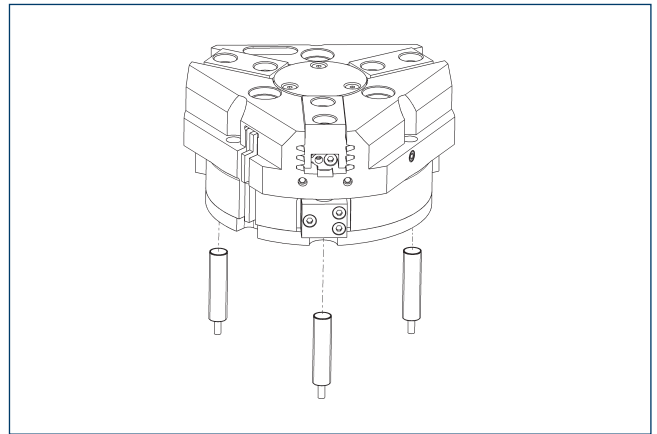

End position monitoring can be mounted with an attachment kit.

Description	ID	
<b>Attachment kit for proximity switch</b>		
AS-RMS 80 PGN/PZN-plus 64/80	0377725	
<b>Reed Switches</b>		
RMS 80-S-M8	0377721	

- ① Two sensors (closer/S) are required for each unit and extension cables are available as an option. This attachment kit needs to be ordered optionally as an accessory. Two mounting kits are required for each gripper. For sensor cables, note the minimum permissible bending radii. These are generally 35 mm.