

Technical Instructions

User Manual

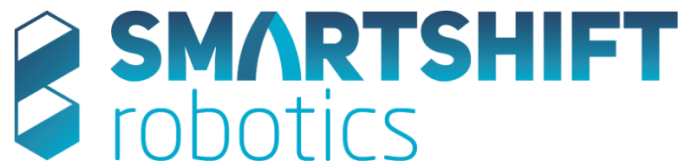

Original instructions User manual

Manufacturer: Smartshift Robotics AS
Machine type: SmartShift
Designation: Tool Change system
Manufacturing year: 2019

Company

Smartshift Robotics AS
Hensmoveien 17
NO-3516 Hønefoss
Phone: +47 92 17 07 80
E-mail: sales@smartshift-robotics.com

Original instructions – User manual

1 Introduction

The SMARTSHIFT clutch/Tool Change system is designed for manual or automatic robotic tool shifting.

The Smartshift Tool Change system is one of, if not the fastest Robot Tool Change system Globally today. We can offer our Tool Change system to Small robots, Collaborative Robots, SCARA Robots, Delta Robots, Small and Large Industrial Robots. SMARTSHIFT basic clutch set consists of three units: A Tool Pocket (TP), a Robot Master (RM), and Tool Holders (TH) with pneumatically connection and optional Electrical (E) connections. Several tool change set variations and application tool selections are therefore possible.

With a fast cycle time Change, Smartshift is giving Robot installation flexibility and increasing the usage of Robots in general. With the “tool belt” equipment of Smartshift, you are ready to automate more tasks, in shorter time, not being bound by Robot choice. Smartshift operates as a Mechanical shifter, and does not interfere with software communication. This way Smartshift supports all manufacturers of Robots and machines that need parallel or multiple tasking operations during an operation.

Variety examples:



Product information:

Machine type: *SMARTSHIFT Clutch*

Drawing number: *X*

Type designation: *xxxxxxx*

Manufacturing year: *2019*

Manufacturer:

Name: *Smartshift Robotics AS*

Reference: *Kjell Buind*

Address: *Hensmoveien 17,*

3516 Hønefoss

Norway

2 Table of Contents

1	INTRODUCTION	2
2	TABLE OF CONTENTS	4
3	GENERAL DESCRIPTION	5
3.1	THE SMARTSHIFT AUTOMATIC AND MANUAL CLUTCH	5
3.2	ROBOT MASTER SPECIFICATIONS	6
3.3	TOOL HOLDER SPECIFICATIONS	6
3.4	TOOL POCKET SPECIFICATIONS	7
3.5	ROBOT MASTER ELECTRICAL SPESIFICATIONS	7
3.6	TOOL HOLDER ELECTRICAL SPESIFICATIONS	8
3.7	SMARTSHIFT SENSOR (Optional Ad on)	9
4	SAFETY INSTRUCTIONS	9
4.1	GENERAL SAFETY	9
5	MOUNTING	10
5.1	SETUP GUIDE TOOL POCKET	10
5.2	SETUP GUIDE ROBOT MASTER	11
5.3	SETUP GUIDE MANIFOLD	12
5.4	PNEUMATIC "Ad on" extended multifunction	13
6	ELECTRIC TOOL CHANGE	15
7	WORK SPACE	16
8	ELECTRIC CABLE CONNECTION	17
9	MAINTENANCE	18
9.1	GENERAL	18
9.2	LUBRICATION	18
10	MOUNTING OF "AD ON" ELECTRIC M8 8 PIN CONNECTOR	19
11	ALIGNED INSTALLING "AD ON"	21
12	GENERAL USAGE	23
13	TCP SETUP	24
14	RUNNING TOOL CHANGE – PICK UP SETUP	25

3 General description

3.1 The SMARTSHIFT Clutch

The automatic and manual SMARTSHIFT clutch is capable of connecting mechanical, pneumatically and electrical tools for robots and consists of following three main units:

A Robot Master (RM), mounted on the robot such as the Universal Robots or similar equipment. Tool Pocket (TP) and Tool Holders (TH) applies in a number and variations depending on demands for tool applications at the robot. In automatic mode, the robot exchange tools in a simple process sequence by placing a Tool Holder (TH) in an empty Tool Pocket (TP) and select another Tool Holder (TH) from another Tool Pocket (TP). Tools also exchanges manually if desired.

Detail Overview

- A) Robot Master (RM)
- B) Tool Holder (TH)
- C) Tool Pocket (TP)
- D) Robot Master with electrical connectors (RME)
- E) Tool Holder with electrical connectors (THE)

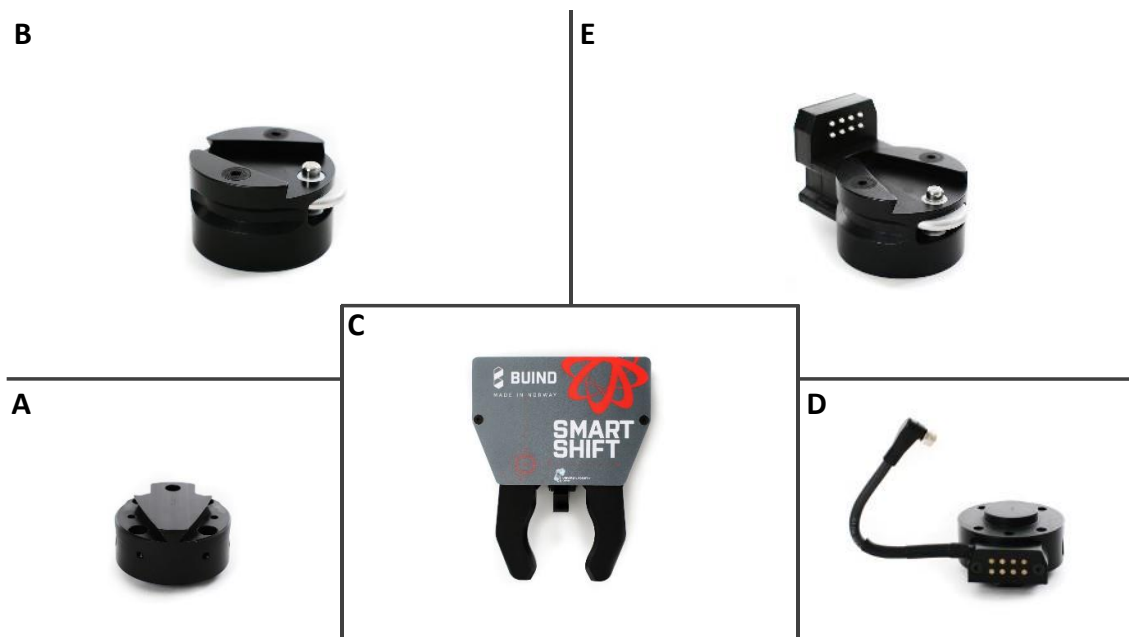

3.2 Robot Master (RM) specification

Recommended for robots handling payload up to: 50 kg
 Pneumatic/Vacuum connection: Double connection with two G1/8"
 Electrical connection: Up to eight pins
 Outer diameter: 63 mm
 Flange diameter 31.5 mm h7
 Reference diameter: \varnothing 50 mm
 Total Weight: 150 g
 Material: POM-C (The entire part is POM-C)

Adapter for other Robot flange fit, on demand/on stock.

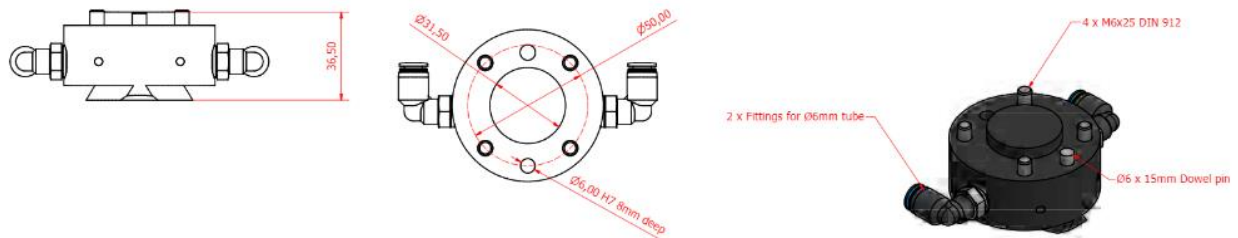

3.3 Tool Holder (TH) specification

Recommended for robots handling payload up to: 50 kg
 Pneumatic/Vacuum connection: Double connection with two G1/8"
 Electrical connectors: Up to 8 pins
 Outer diameter: 63 mm
 Flange diameter 31.5 mm h7
 Reference diameter: \varnothing 50 mm
 Total Weight: 255 g
 Material: Aluminium 6082-T6 Anodized (Tool holder and Disc) stainless steel (Locking pin),
 Rubber (Air pass through sealants)

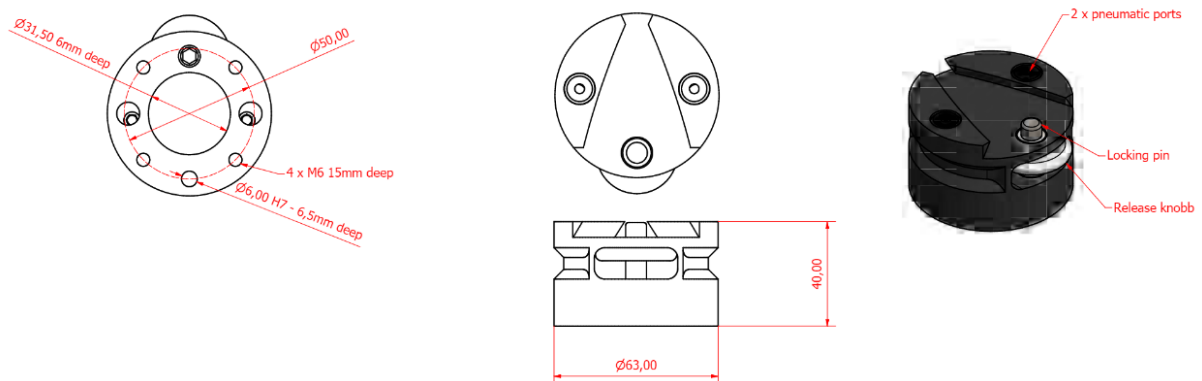

3.4 Tool Pocket (TP) specification

Recommended handling weight: Up to 5 kg

Total weight: 710 g

Materials: Aluminium 6082-T6 Anodized (Bottom plate, top plate), POM-C (Gripper holder arms), stainless steel EN10278 (Spacers) PVC (Sticker)

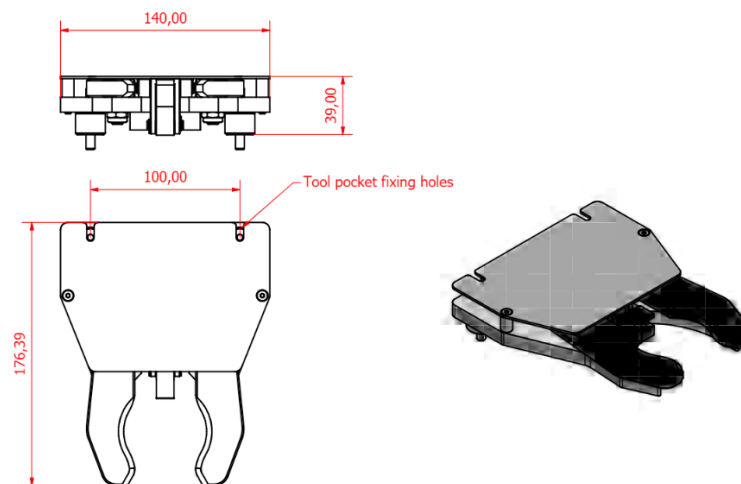

3.5 Robot Master Electrical (RME) specification

Recommended for robots handling payload up to: 50 kg

Pneumatic/Vacuum connection: Double connection with two G1/8"

Electrical connection: Up to eight pins

Outer diameter: 63 mm

Flange diameter 31.5 mm h7

Reference diameter: \varnothing 50 mm

Total Weight: 180 g

Material: POM-C (The entire part is POM-C)

Eight pins electrical pass-through rated for 1.0 AMP per 8 pin

Materials: Brass, Silver coated, copper cable, ABS plastic

IMPORTANT: Power connection must be OFF during clutching in and out. A charged pin will create a spark that will destroy the connector pins by welding/burns.

Adapter for other Robot flange fit, on demand/on stock.

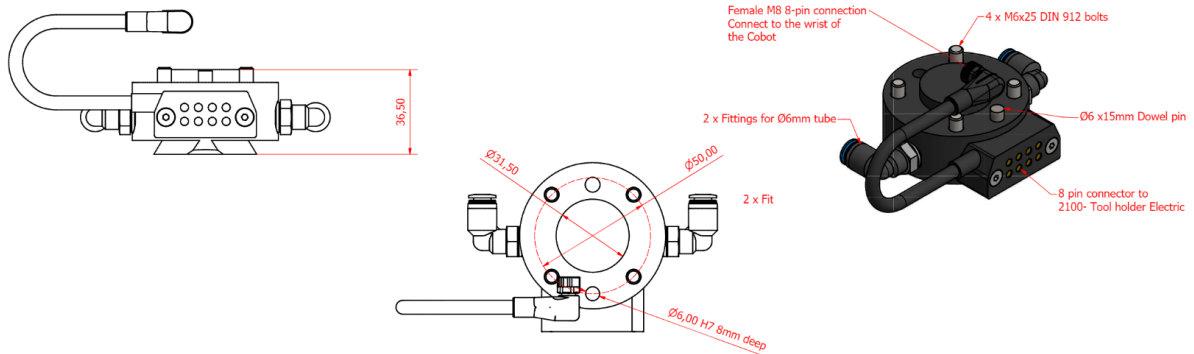

3.6 Tool Holder Electrical (THE) specification

Recommended for robots handling payload up to: 50 kg

Pneumatic/Vacuum connection: Double connection with two G1/8"

Electrical connectors: Up to 8 pins

Outer diameter: 63 mm

Flange diameter 31.5 mm h7

Reference diameter: Ø 50 mm

Total Weight: 310 g

Material: Aluminium 6082-T6 Anodized (Tool holder and Disc) stainless steel (Locking pin), Rubber (Air pass through sealants)

Eight pins electrical pass-through rated for 1.0 AMP per 8 pin

Materials: Brass, Soldering tin, copper cable, ABS plastic

IMPORTANT: Power connection must be OFF during clutching in and out. A charged pin will create a spark that will destroy the connector pins by welding/burns.

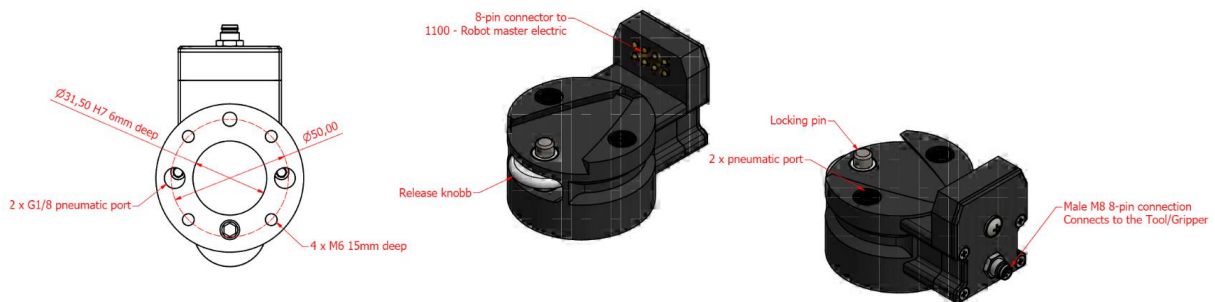

3.7 Smartshift sensor (Optional Ad on)

Using Inductive sensor, Smartshift provides, on demand, a safety function to its clutch system. The sensor is mounted in the Robot Master (RM) on delivery (on demand add on) or can be delivered on the side for installation by the end user. The sensor works as a safety and stop function, using the Inductive sensor to communicate with the Robot. The sensor function is to prevent pore connection on pick up (ex. Dusty environment) or missed pick up in general.

The sensor detects Inductive if the lock pin on the Tool Holder (TH) is in correct lock position inside the Robot Master (RM).

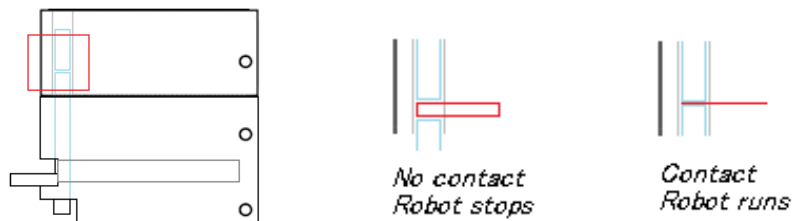

4 Safety instructions

4.1 General safety

Keep hands and tools away from all SMARTSHIFT components when the program is running.

Follow this manual carefully also regarding maintenance and recommended weight. Always have security data sheet for recommended lubrication available.

If the SMARTSHIFT clutch is damaged, then stop using immediately and contact Smartshift Robotics AS for replacement parts. Notice that the Tool Pocket and Tool Holder is spring loaded and the electrical units carries current. Smartshift is not responsible for damage to people and property caused by using damaged components.

5 Mounting

Mount Robot Master (RM) directly onto the Robot flange or on similar equipment using the provided flange mounting screws. If flange fit is other than standard Smartshift unit, use provided adapter. If no adaptor is supplied, contact Smartshift Robotics AS.

Mount the Tool Pocket (TP) horizontally and place it so that the robot easily can pick and place Tool Holders (TH) from Tool Pocket (TP). Mount the tool for your application on the Tool Holder (TH), recommended handling weight is 5.0 kg. The owner is fully responsible for mounting the SMARTSHIFT clutch securely.

5.1 Setup guide Tool Pocket

Unscrew the top plate by loosening the two M4 screws.

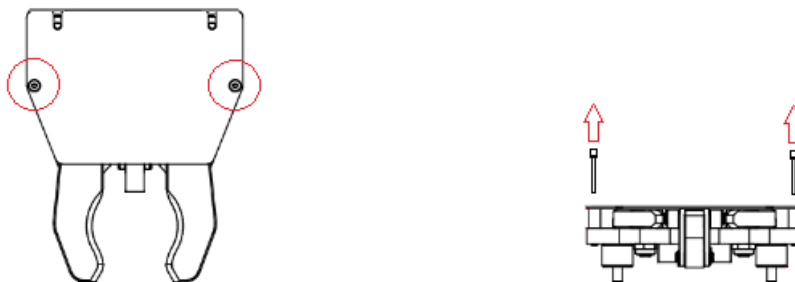

Remove the top-plate and the two cylindrical spacers under the top-plate.



Put two M6 screws through the two mounting holes on top of the gripper plate and through the two larger cylindrical spacers provided (see mount units bag attached on delivery).

Put the gripper on top of a flat and stable surface with threaded holes and tighten down the two M6 screws.



Put the top-plate back on the gripper with the spacer cylinders and tighten down the two M4 screws just enough to keep the top plate from moving

5.2 Setup guide Robot Master

Smartshift mounting of Robot Master is intended directly on to the Robot (of choice) flange connection. Smartshift delivers a standard size:

Outer diameter: 63 mm
 Flange diameter 31.5 mm h7
 Reference diameter: \varnothing 50 mm

The 4 screw connection (included on delivery) is to be mounted directly on to the Robot flange with a force of no more than recommended 3 Newton (N) / 26,552 in.lbf to ensure the Smartshift unit is accurately mounted. More pressure than the recommended force could result in damage or uneven surface that can inflict on the accuracy pick up of the Robot Master (RM) and Tool Holder (TH). If damaged, tightened to hard and an even pick up is registered, Smartshift suggests loosening the pressure back to recommended tightening strength or contact Smartshift Robotics AS for service, repair or replacement of part. If no Torque tool, we recommend using the Umbraco as shown.

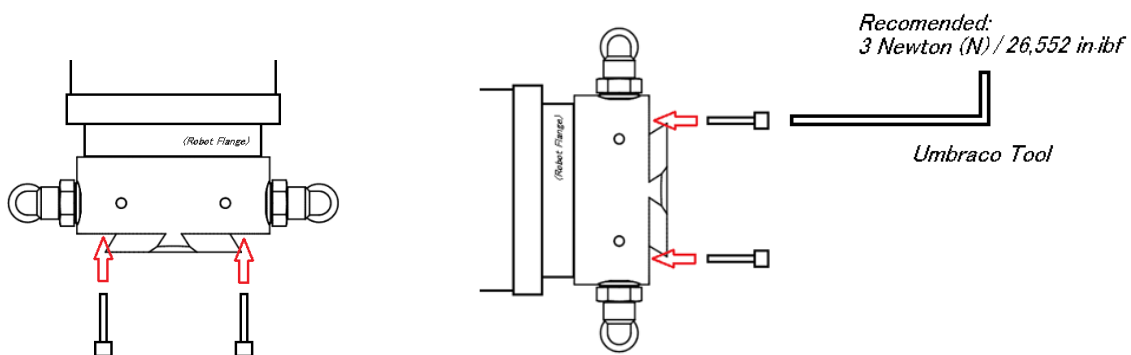

If there is no accurate fit to the Robot flange, contact Smartshift Robotics AS for a adaptor to fit the connection.

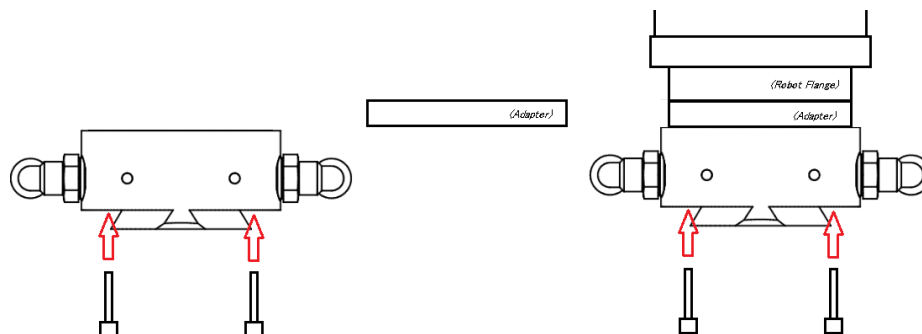

5.3 Setup guide Manifold (pneumatic)

Smartshift delivers every item with Pneumatic functionality. By using Pneumatic/Vacuum connection: Double connection with two G1/8", use of compressed air is installed on all units on delivery.

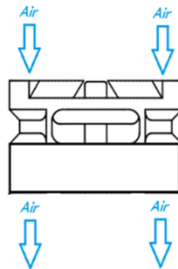

Smartshifts unique solution to the use of Pneumatics is based on the Toll side of the functionality. The Manifold is the component that directs the air out from the sides, under the Tool Holder (TH). With two G1/8", Smartshift's solution to handling complex and multi functional vacuum applications is either using:



two air ports for vacuum

two ports for compressed air

one port for vacuum and one for compressed air

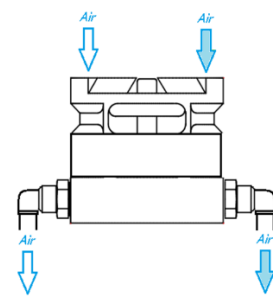
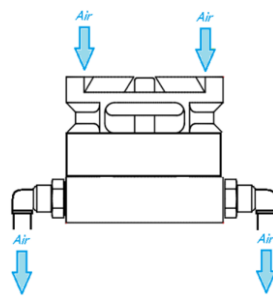
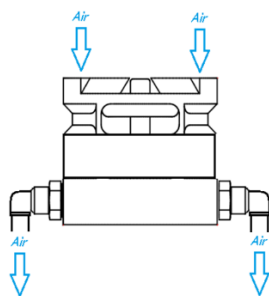

Smartshift Manifold is to be used if the air is to be directed out on the sides and not directly into the tool, mounted on the Tool Holder (TH).

In many cases there is NO NEED for the Smartshift Manifold, since the air is to be connected directly into the tool, from under the Tool Holder (TH).



5.4 Pneumatic “Ad on” extended multifunction

Smartshift Collaborative and small Industrial Robot Tool Change system is delivered with Double connection with two G1/8”. When, or, if in need of more or several pneumatic ports, the Smartshift pneumatic solution is built with the intention and purpose to remove all unnecessary cabling and tubing’s along the Robots flange area. This way Smartshift provides safety in terms of potential damage when using a Robot in a multitask and high tech solution environment.

With the two pneumatic ports, Smartshift can lift the payload equal to the payload max weight of the Tool Change system. Max lift capacity set at 50 Kg payload. This depending on correct use of vacuum cups in size, surface arranged equipment and quantity needed.

The Smartshift pneumatic “Ad On” multifunction recommend the use of a pneumatic steering block included “BUS” connection for signal transfer and technical use. By using the M8 8 pin connecting cables (suggested is the Industrial version, or, cutting of the M8 connector) wiring is needed to attached the pneumatic steering block. Be sure to use professional assistance(Smartshift is not eligible for any damage done by non-certified personnel) when wiring.

When using a pneumatic steering block, you can increase numbers of airports from 2 pneumatic ports using multi use tooling and also if need upgrade to Bus for signal transfer.

(Picture example: Pneumatic steering Block FESTO VTUG-10-MSDR-B1TZ-25V20-Q10L-UL-Q6S-6P, giving 7 airports and option for Bus communication)

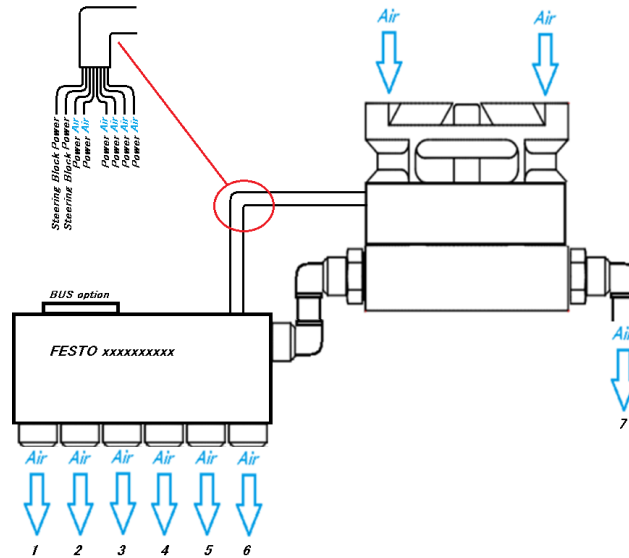

If in need of extra supply of air pressure, the second air port on the Tool Holder (TH) can be added on to the steering Block. (Picture example: Pneumatic steering Block FESTO VTUG-10-MSDR-B1TZ-25V20-Q10L-UL-Q6S-6P)

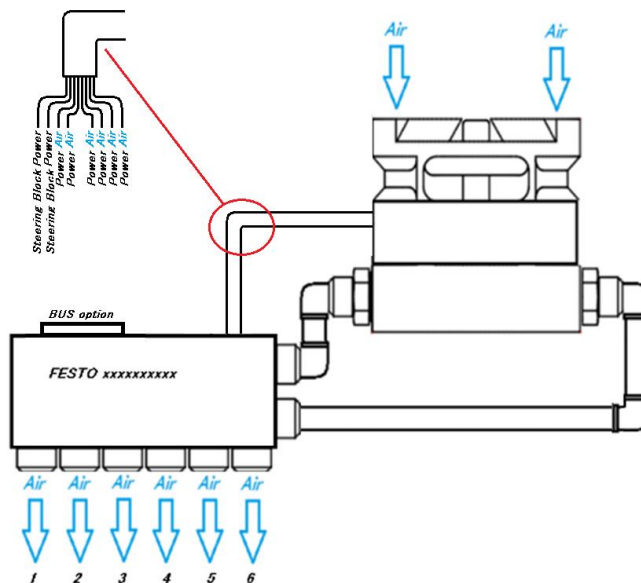

6 Electric Tool Change

When running an electric tool change sequence, it is important to remember switching on and off the electric flow.

Example: Robot + Smartshift Tool Change + electric tool.

When running this operation there will be a constant power flow from the robot to the electric tool. Smartshift electric tools are a pure pass-through unit and does not regulate the power flow when using the Tool Change system. This way you need to create an On/Off move when picking up or delivering the electric tool in the Tool Pocket (TP). Not creating this command on the robot may damage the Robot or electric tool due to short-circuit damage. Being a mechanical system with only pure pass-through function, Smartshift is not eligible for any damage to the use of external units.

When pick up of tool, turn off power supply to tool. Once tool is picked up, turn power supply on again. The same is done on delivery in the opposite direction.

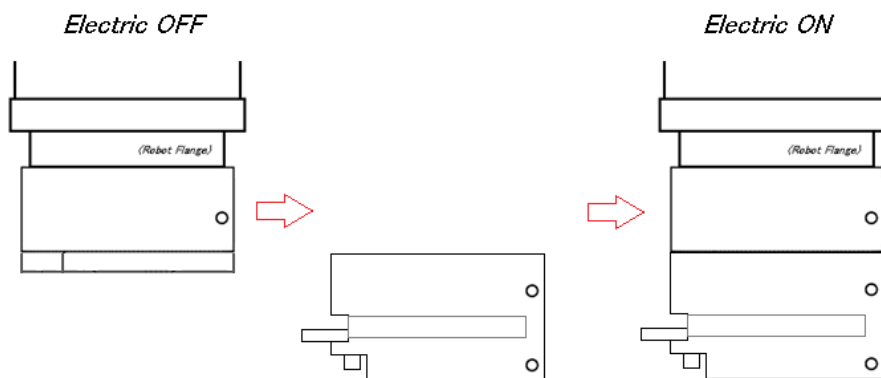

7 Work space

Smartshift Tool Change system has a 50 Kg Payload max work force (the Tool Change units used + weight on what the Robot will be lifting). The Tool Change system has a repeatability of 0.05mm measured within the “Green zone” of the Tool Change measurement system. Working outside of this area the repeatability may exceed the 0.05mm accuracy from TCP (Tool centre point).

Smartshift accuracy is measured at:

Horizontal distance from scenter TCP 0 cm to 7,5 cm.

Vertical distance from scenter TCP 0 cm to 30 cm.

Degrees (hot/cold) work environment set at +5 / + 40 C. (At low temperature below 0 C and above +40 C the Smartshift tool can still be run, but increased friction out side the 0.05 mm repeated accuracy between Master (RM) and Tool Holder (TH) may be exceeded.)

At low weight, repeatability may though be accurate even with extended tool ad-on. If deviation accrues Smartshift suggest centring the on mounted tooling for more accurate repeatability, or use off loader support systems.

General explanation; closer to TCP – higher payload.

Examples: Heavy weld Torch, uneven rods and poles, uneven balanced tools.

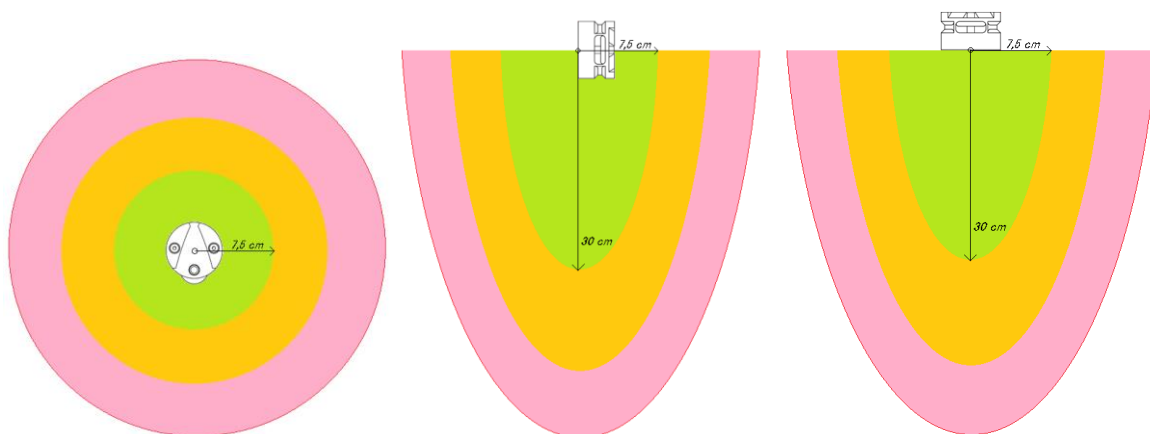

8 Electric Cable connection

Collaborative Robots

Smartshift uses as standard M8 8 pin 24 V AMP, Female and Male connector.

The connectors are generally used as standard connectors on the Collaborative robots. Female, Male, or both Female and Male connectors vary from manufacturer to manufacturer. When installing a Smartshift Robot Master on to the flange connection on a Collaborative robot with the M8 8 pin connector, Smartshift Robot Master installs as a plug-n-play function. **IMPORTANT!** Be sure to have the correct connector match. *(Example; Male connector on flange of robot – Female connector on Smartshift Robot Master – Then Male connector on Smartshift Tool Holder.)*

Smartshift also offers the standard M8 8 pin connectors as ad-on. (See catalogue) The M8 8 pin connector ad on units makes Smartshift unique, functioning as a “lego” system where you can upgrade existing units without electric connection, or unmount the electrical connection ad on if no need for electrical use.



Industrial Robots

Smartshift uses as standard M8 8 pin 24 V AMP, Female and Male connector. When installing the Smartshift Robot Master on Industrial robots you need the Industrial version of the M8 8 pin connector. This connector is delivered without the M8 8 pin flange connector. Installation is done directly on to the electrical system on the Industrial Robot wiring or electric junction box. Standard length of cable set at approx. 1 meter. Can be ordered at other length on demand.



9 Maintenance

9.1 General

Make sure to keep SMARTSHIFT in a clean environment. If chips or other big particles comes between the Robot Master (RM) and the Tool Holder (TH) the lifetime of the SMARTSHIFT system can be shortened. Smartshift also recommends air blow cleaning.

9.2 Lubrication

Once every second week, put a few drops of silicon-based lubricant (silicone spray) on each rubber seal, a few drops on each surface to keep the components sliding easily against each other, and a few drops on the locking pin to, keep the pin sliding easily. Recommended silicone spray is WD-40 300014 silicone oil, or equivalent silicone-based lubricant.

Silicon Lubricant to be used on: V-shaped connection area, lock pin, lock wheel and (important) sealing of pneumatic connections.



10 Mounting of Ad on Electric M8 8 pin connector to Master and Tool Holder unit

Smartshift Tool Change system is an ad on system that allows you to choose from mechanical manual or automatic change system, pneumatic system and electric (pass through) system. The Change system is made for ease to install or uninstall the functionality you are, or are not to use. The M8 8 pin connector system can be ordered attached and installed or separately for installation at a later time when in need. The M8 8 pin connector consists of an electric unit attached to the Master (RM), and one unit attached to the Tool Holder (TH). For electric function you are to need both units to connect together.

The complete electric system is set up as a “opposite” connection system.

If the Robot has the Male connector, you are to need a Female Smartshift Master (RM) connector, then a Male Tool Holder connector. The opposite function is needed if you have a Robot with a Female connector, you are to need a Male Master connector (RM), then a Female Tool Holder connector.

When installing the electrical ad on, you are to install the units carefully for a functional fit.

When installing the Master (RM) electrical M8 8 pin ad on, you can use the supplied (or use purchased) M4 x 4 bolts added on delivery. The tightening of the M8 8 pin Master electrical unit can be tightened well. No need of controlled force.

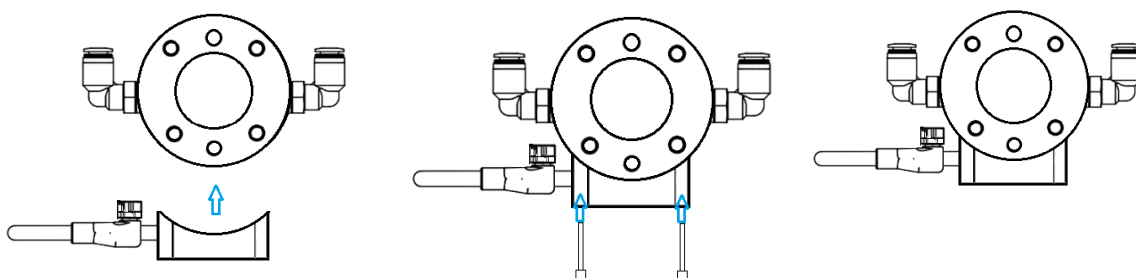

When installing the Tool Holder (TH) electrical M8 8 pin ad on, you can use the supplied (or use purchased) M4 x 4 bolts added on delivery. When tightening of the M8 8 pin Tool Holder (TH) electrical unit it is very important to NOT over tighten the bolts. The unit must be carefully tightened so that the space between the (already tightened) Master M8 8 pin connector and the Tool Holder M8 8 pin connector has a space between 1-1,5 mm of distance.

It is important to use the “crossover” tightening method (like when tightening a wheel on a car) to ensure it is not tightened unevenly, tilting or angling un aligned, but is set up even and vertical in the connection (see pic). This tightening must be done with precision and ease to make sure the connections are aligned. Smartshift encourage end users to purchase finished installed units, but in case of after installation use the following steps to be sure the connection is aligned and functional. If connection is not responding on all 8 of the M8 8 pin connections, re install the unit for an aligned installation.

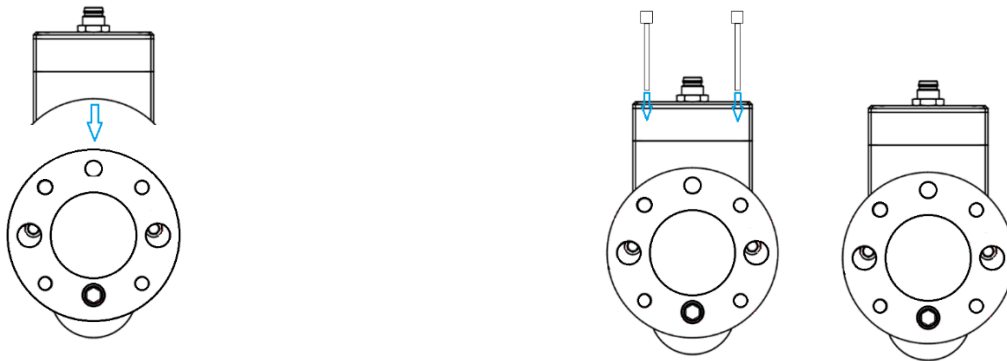

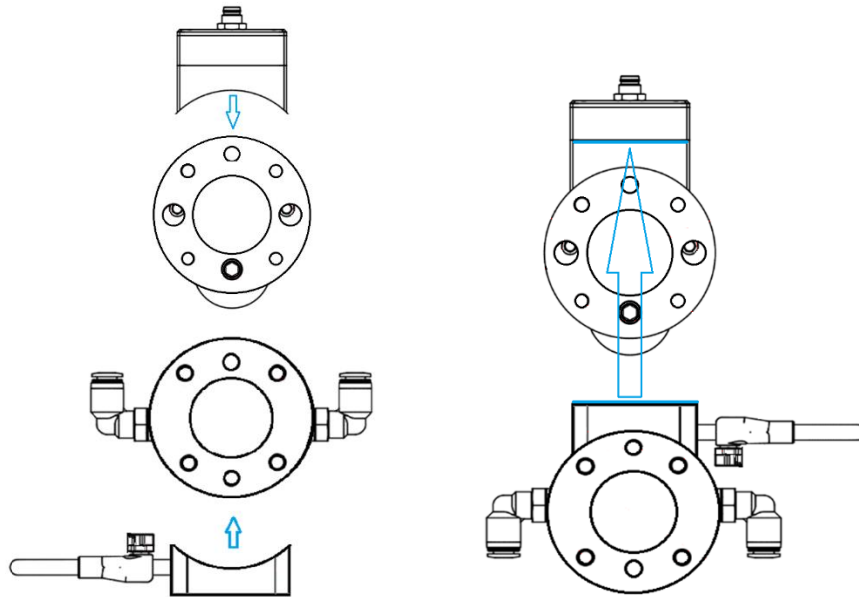

11 Aligned Installing Electrical Ad on

When installing the electrical components (ad on) the important factor of the installation is the mounting of the Tool Holder (TH) unit. Be sure to address the connection and connection bolts addressed in the manual and supplied on delivery. The connection sequence is: Male (towards) Female, or opposite. Sliding the Horizontal function, the Smartshift will now execute a perfect connect and dis connect sequence.

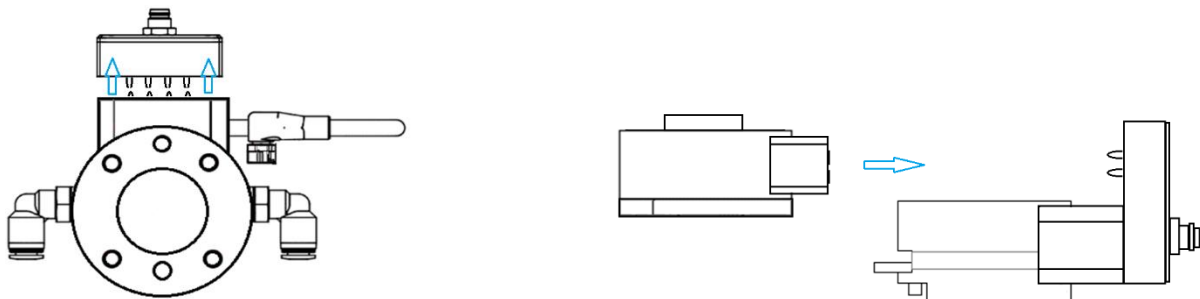

While mounting the connector ad on units, an important factor is to ensure the connection is in correct order.

Be sure to use the “car wheel phenomime” cross tightening when tightening the bolts on the Tool Holder (TH). The connection will be connecting accurate when the Master (RM) connector and the Tool Holder (TH) connector is aligned and even in its location. An important factor in this installation is also to ensure the electric connector on the Tool Holder (TH) unit is not squeezed to tight. If so, the unit connector may be tilted unevenly, creating a non-linear interaction.

If the Connection is not functional, repeat the installation, as shown below:

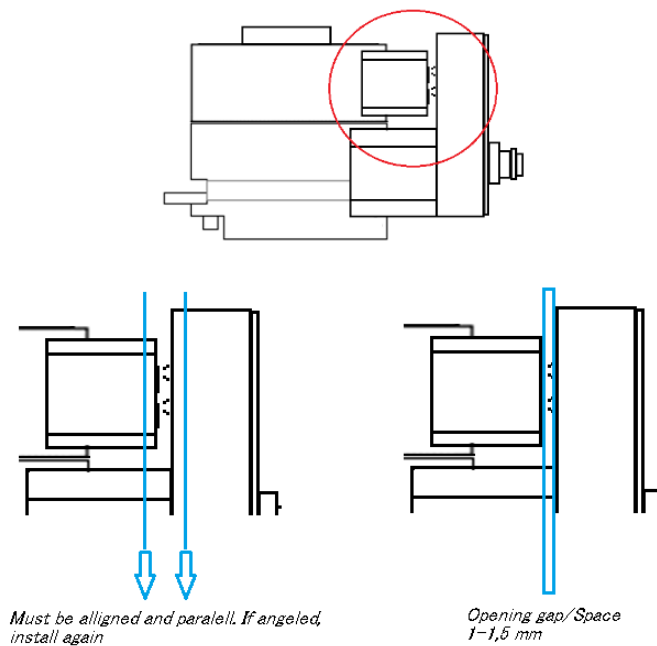

When connecting the wires on the Smartshift Tool Change system, be ware to follow the pre-installed pattern of wires for the electrical system.

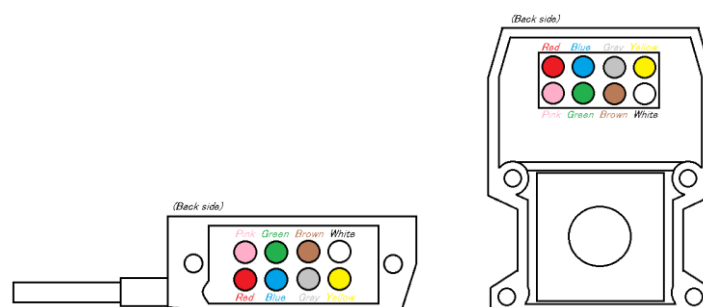

12 General usage

The Smartshift Tool Change system is made to increase the Robot and Machine usage in terms of cycle time and repetitive tasks. With the ease of use function and adaptability use of the Smartshift, covering any Robot and Machine manufacturer specification, the Smartshift Tool Change system is a system that “fits all” and modifies to any purpose and Robot type (Collaborative, Small Industrial, SCARA, Delta, +).

Tests have shown Smartshift running a Tool Change speed of 120 changes in 40 sec.

If the Robot function, adaptation, size, weight or other functionalities obstacle should accrue. Smartshift develops, manufacture, adapts and supplies all Robot needs and machine needs when it comes to multi tasking, robot application and general usage where short ROI is desired to install a Robot or machine cell.

Tests have shown Smartshift running a Tool Change cycle of 800 000 shifts and still no damage.

“120 Accurate Changes per 40 sec.”

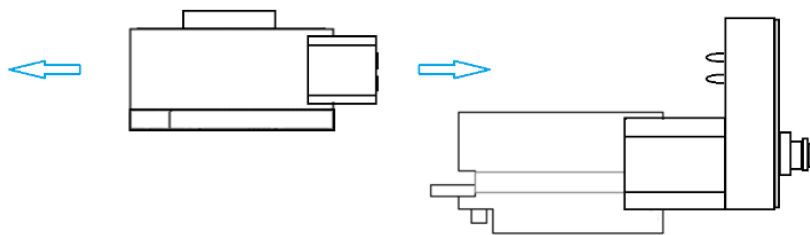

13 TCP setup

When setting up the TCP (Tool Centre Point) on your Robot, with Smartshift, use the following information.

The Tool Change system, Master (RM) + Tool Holder (TH), has a height of 65 mm total when connected together. You must then include/add on the 65 mm when measuring from the Robot Flange and to your TCP on tool of choice (for instance a Grippers or welding torch etc.).

Weight Automatic Tool Change units

Robot Master	150 gram	(non el.)
Robot Master Electric	180 gram	
Tool Holder	255 gram	(non el.)
Tool Holder Electric	310 gram	
Manifold	110 gram	

(more specifications; www.smartshift-robotics.com, catalogue)

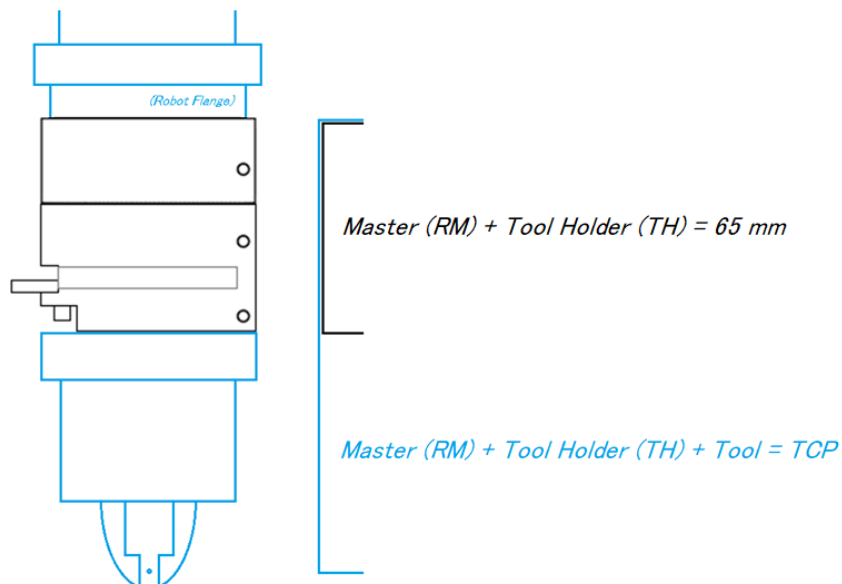

14 Running Tool Change operation – Pick up setup

Setting up a pick up and drop of the Tool Holder (TH) in to and out of the Tool Pocket (TP) is a simple operation done in minutes. By following the 3-step procedure, the setup will be secure and running correct. Key words are: Horizontally levelled Master (RM), and Vertically angled Master (RM). If the Master (RM) is tilted at an angle, pick up will not be smooth and the Robot can possibly push the Tool Holder out of the Tool Pocket (TP) under pick up move. For accurate return, Smartshift suggests to first run and log pick up direction, then copy the same way points for return and delivery.

POS. 1:

Place Robot with Smartshift Master (RM) above the backend of the Tool Pocket (TP).

POS. 2:

Lower the Robot with Smartshift Master (RM) down to the Tool Pocket, making sure the bottom end of the Master (RM) is placed a few millimetres from the cover plate of the Tool Pocket (TP).

POS. 3:

Run the Robot with the Smartshift Master (RM) horizontally and aligned straight forward through the Tool Holder (TH) that is placed in the Tool Pocket (TP) out in front of the Tool Pocket (TP).

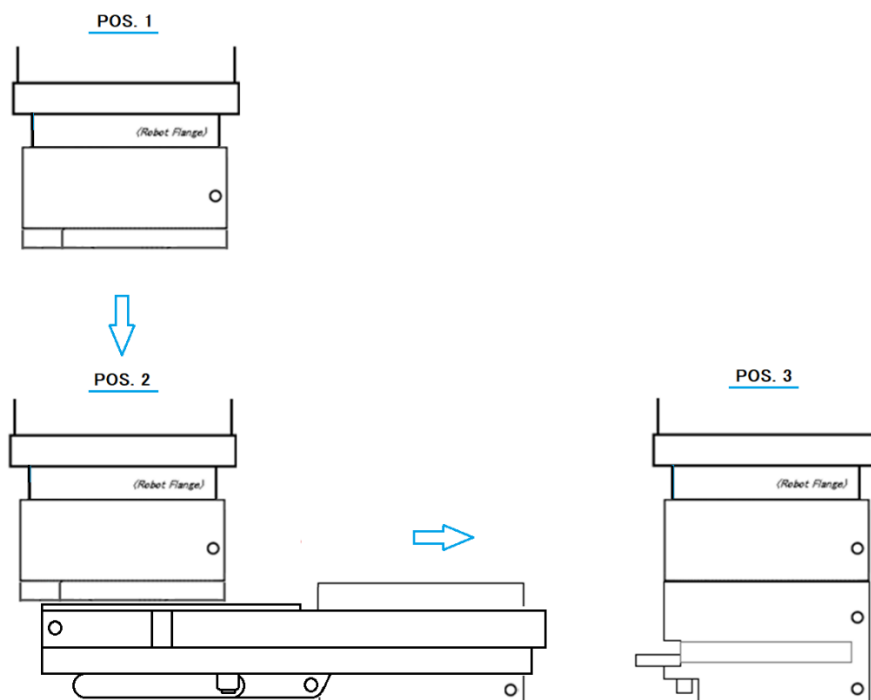

When moving from POS. 2, to POS. 3, be sure to align the Robot path both Horizontally and directly out of the Tool Pocket (TP) Vertically aligned.

Do not add another way point between POS.2 and POS.3. Smartshift Tool Change system is a mechanical system that is spring feathered tightened in the Tool Pocket (TP). To make an accurate pick up you need a one movement path going over and out of the Tool Pocket (TP). By using a one movement path between POS.2 and POS.3, the Tool Pocket (TP) (set at 5.0 Kg payload) have solved accurate pick up down to 3.0 Kg payload Robots.

