

Ball Check Order/Quote Form

Check all that apply:

- | | | | |
|---|---|---|---|
| <input type="checkbox"/> Hi-Flow Ball Check | <input type="checkbox"/> CPM® 9V® | <input type="checkbox"/> Shear Sensitive | <input type="checkbox"/> Other: |
| <input type="checkbox"/> Side Discharge Ball | <input type="checkbox"/> CPM 9V + Nitride | <input type="checkbox"/> Corrosive | <input type="checkbox"/> CPM S90V® (SS) |
| <input type="checkbox"/> Front Discharge Ball | <input type="checkbox"/> General Purpose | <input type="checkbox"/> High Speed Molding | |
| | <input type="checkbox"/> Abrasive | <input type="checkbox"/> Carbide Inserts | |

Use Standard or Metric measurements.

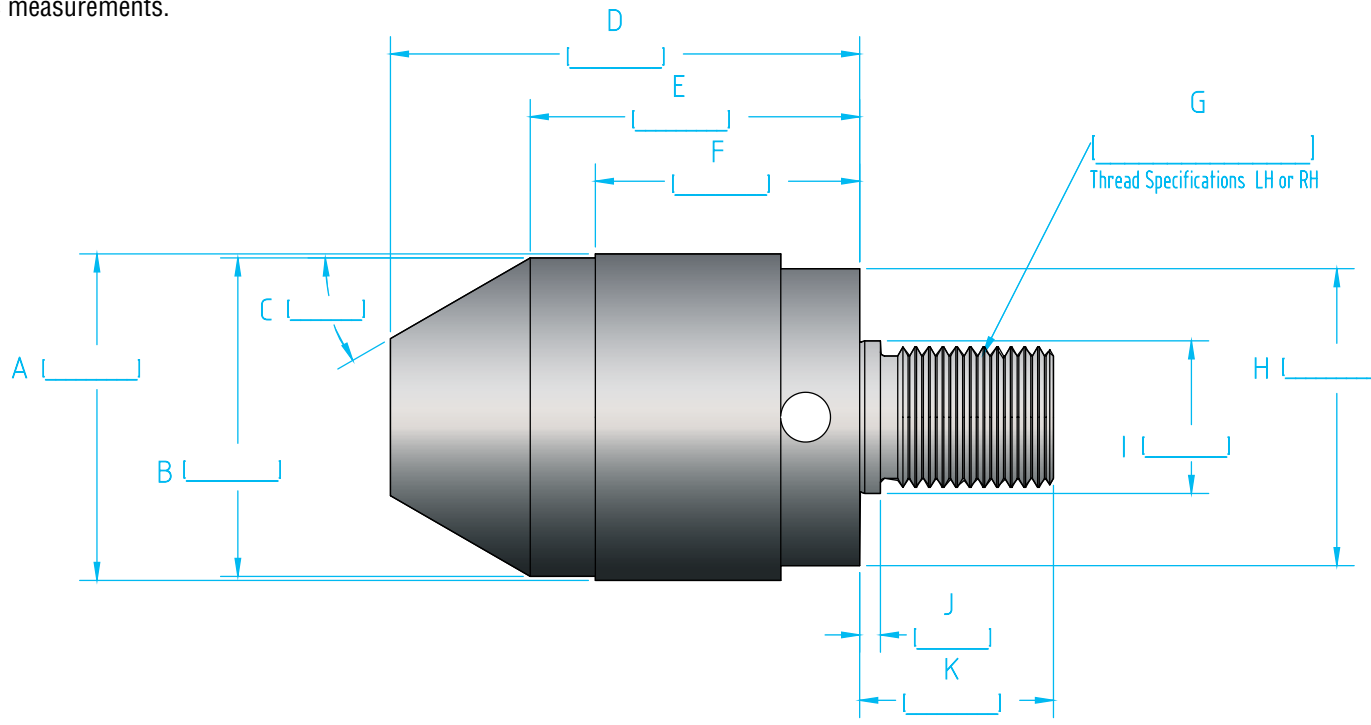

Machine Make: _____

Company: _____

Tonnage: _____

Name: _____

Oz. Capacity: _____

Telephone: _____

Serial #: _____

Fax: _____

Date: _____ Quote Order

Email: _____